

UNIVERSITY OF CALIFORNIA  
Santa Barbara

Hierarchical Transactions for Hardware/Software  
Cosynthesis

A Dissertation submitted in partial satisfaction  
of the requirements for the degree of

Doctor of Philosophy

in

Computer Engineering

by

Kunal Arya

Committee in Charge:  
Professor Forrest Brewer, Chair  
Professor Timothy Sherwood  
Professor Li-C. Wang  
Professor Tefvik Bultan

December 2014

The Dissertation of  
Kunal Arya is approved:

---

Professor Timothy Sherwood

---

Professor Li-C. Wang

---

Professor Tefvik Bultan

---

Professor Forrest Brewer, Committee Chair

September 2014

Hierarchical Transactions for Hardware/Software Cosynthesis

Copyright © 2014

by

Kunal Arya

## Abstract

# Hierarchical Transactions for Hardware/Software Cosynthesis

Kunal Arya

Modern heterogeneous devices provide of a variety of computationally diverse components holding tremendous performance and power capability. Hardware-software cosynthesis offers system-level synthesis and optimization opportunities to realize the potential of these evolving architectures. Efficiently coordinating high-throughput data to make use of available computational resources requires a myriad of distributed local memories, caching structures, and data motion resources. In fact, storage, caching, and data transfer components comprise the majority of silicon real estate. Conventional automated approaches, unfortunately, do not effectively represent applications in a way that captures data motion and state management which dictate dominant system costs. Consequently, existing cosynthesis methods suffer from poor utility of computational resources. Automated cosynthesis tailored towards memory-centric optimizations can address the challenge, adapting partitioning, scheduling, mapping, and binding techniques to maximize overall system utility.

This research presents a novel hierarchical transaction model that formalizes state and control management through an abstract data/control encapsulation semantic. It is designed from the ground-up to enable efficient synthesis across heterogeneous system components, with an emphasis on memory capacity constraints. It intrinsically encourages a high degree of concurrency and latency tol-

erance, and provides verification tools to ensure correctness. A unique data/execution hierarchical encapsulation framework guarantees scalable analysis, supporting a novel concept of state and control mobility. A front-end language allows concise expression of designer intent, and is structured with synthesis in mind. Designers express families of valid executions in a minimal format through high-level dependencies, type systems, and computational relationships, allowing synthesis tools to manage lower-level details. This dissertation introduces and exercises the model, discussing language construction, demonstrating control and data-dominated applications, and presenting a synthesis path that exhibits near-linear scalability with problem size.

*To my family, for their love, support, and joy. To Hinal, who always managed to put a smile on my face. To my friends who kept me in good spirits and (perhaps more importantly) kept me on my toes. To Forrest, for sharing his enthusiasm, consideration, time, and singularly unique approach to engineering.*

# Contents

<b>List of Figures</b>	<b>xii</b>
<b>List of Acronyms</b>	<b>xvi</b>
<b>1 Introduction</b>	<b>1</b>
1.1 From Codesign to Cosynthesis . . . . .	3
1.1.1 The Case for Cosynthesis . . . . .	4
1.1.2 The State of the Art . . . . .	5
1.1.2.1 Exposing and Modeling Dominant System Costs	6
1.1.2.2 A Symbiotic Development Relationship . . . . .	6
1.2 Contributions . . . . .	7
1.2.1 Computational and State Mobility . . . . .	8
1.3 Overview . . . . .	9
<b>2 State of the Field</b>	<b>11</b>
2.1 Behavior and State Representation Models . . . . .	13
2.1.1 Early Computing Models . . . . .	13
2.1.2 Moving Towards Novel Models . . . . .	14
2.1.3 Data-flow and Task Graph . . . . .	15
2.1.4 Latency Tolerance . . . . .	16
2.1.5 Transactions, TLM, and Transactors . . . . .	17
2.1.5.1 Transaction Level Modeling . . . . .	17
2.1.5.2 Synthesizable TLM . . . . .	17
2.1.5.3 Nested Transactions and Software Transactional Memories . . . . .	18
2.1.5.4 Transactors . . . . .	19
2.1.6 Hardware/software Partitioning . . . . .	19
2.1.7 An Overview of Cosynthesis Models . . . . .	20

2.1.7.1	Magellan . . . . .	21
2.1.7.2	Metropolis . . . . .	22
2.1.8	Bluespec . . . . .	23
2.2	Software-to-RTL . . . . .	24
2.2.1	Model Representation . . . . .	25
2.3	Moving Towards Hierarchical Transactions . . . . .	26
<b>3</b>	<b>Hierarchical Transactions</b>	<b>27</b>
3.1	Abstraction . . . . .	27
3.2	Challenges in Cosynthesis . . . . .	28
3.3	Semantic Model . . . . .	31
3.3.1	Hierarchical Transactions . . . . .	31
3.3.2	Overview . . . . .	33
3.3.3	Computational and State Mobility . . . . .	34
3.3.4	Token-based Control . . . . .	35
3.3.4.1	Combining and Forking Tokens . . . . .	36
3.3.5	Latency Tolerance . . . . .	37
3.3.6	Upholding Abstraction . . . . .	39
3.3.7	Concurrency . . . . .	39
<b>4</b>	<b>Hierarchical Guarded Atomic Rule-based Language</b>	<b>41</b>
4.1	Introduction . . . . .	41
4.1.1	Existing Languages . . . . .	42
4.1.2	Aesthetics . . . . .	43
4.2	Core Language Philosophy . . . . .	44
4.2.1	Concision, Meaning, and Abstraction . . . . .	44
4.3	Rule-based Language . . . . .	45
4.3.1	Meta-language vs Language . . . . .	46
4.4	Syntax . . . . .	47
4.4.1	Rules . . . . .	49
4.4.2	Atomicity . . . . .	51
4.4.3	Conditional Statements . . . . .	52
4.4.4	Rule Instances . . . . .	53
4.4.4.1	Rule Instance Syntax . . . . .	53
4.4.5	Functional Rule Instances . . . . .	55
4.4.6	Classes . . . . .	56
4.4.6.1	Instantiation . . . . .	57
4.4.6.2	Parameters . . . . .	57
4.4.7	Parametric Class Examples . . . . .	58
4.4.7.1	Complex Class . . . . .	59



4.4.7.2	Matrix Class . . . . .	59
4.4.8	Modifiers . . . . .	60
4.5	Compiler . . . . .	60
4.5.1	Parsing . . . . .	61
4.6	Static Analysis . . . . .	63
4.6.1	Static Analysis for Constant Inference . . . . .	63
4.6.1.1	Local vs. Global . . . . .	65
4.6.1.2	AST-level Constant Inference . . . . .	65
4.6.1.3	Rule-level Constant Inference . . . . .	67
4.7	Simulator . . . . .	68
<b>5</b>	<b>Iterators</b> . . . . .	<b>69</b>
5.1	Motivation . . . . .	69
5.2	The Array Primitive . . . . .	70
5.3	Communicating Designer Intent . . . . .	71
5.4	Execution Semantics . . . . .	71
5.5	Syntax & Semantics . . . . .	72
5.5.1	Token Scoping . . . . .	72
5.5.2	Sequential vs. Concurrent Iterators . . . . .	73
5.5.3	Multiple Iterators through Co-iteration . . . . .	74
5.5.4	Ordering of Iterator versus Iterator Execution . . . . .	74
5.6	Built-in Iterators . . . . .	75
5.7	FFT through Iterators . . . . .	75
<b>6</b>	<b>Practical Analysis and Model Translation</b> . . . . .	<b>79</b>
6.1	Closure & Distributed Transaction Control . . . . .	80
6.2	Race Condition Detection . . . . .	84
6.2.1	Mutually Concurrent Sets . . . . .	86
6.2.2	Dependency Classifier Matrix . . . . .	87
6.2.3	Mutual Concurrent Set Construction . . . . .	88
6.2.4	Performance . . . . .	89
6.2.5	Isolating and Reporting Race Conditions . . . . .	90
6.3	Conversion into Existing Semantic Models . . . . .	93
6.3.1	Transactions to Pure Functions . . . . .	93
6.4	Transactions to Control/Data-Flow Graphs . . . . .	95
6.4.1	Flow-graphs from Iterators . . . . .	99
6.4.2	Software Scheduling . . . . .	100

<b>7</b>	<b>Control-Dominant Application Study</b>	<b>101</b>
7.1	The MSP430 Microprocessor . . . . .	102
7.2	Processor Specification . . . . .	102
7.2.1	Decoding . . . . .	103
7.3	Race Condition Detection . . . . .	105
7.3.1	The Original Problem . . . . .	105
7.4	Transactional Simulator . . . . .	108
7.5	Direct-to-RTL Realization . . . . .	109
<b>8</b>	<b>High Performance Arithmetic Applications</b>	<b>110</b>
8.1	Memory Capacity and Data Motion . . . . .	111
8.2	Problem Setup . . . . .	111
8.2.1	Commercial IP Options . . . . .	112
8.2.2	Challenges in Digraph Clustering . . . . .	113
8.3	Scheduler-Driven Partitioning . . . . .	114
8.3.1	8-point FFT Clustering Illustration . . . . .	117
8.3.2	Target Algorithms . . . . .	118
8.4	Results . . . . .	120
8.4.1	FFT . . . . .	120
8.4.2	Matrix Multiplication . . . . .	123
8.4.2.1	Complex DSP Algorithm . . . . .	127
8.4.3	Utility and BRAM vs SPM Effectiveness . . . . .	128
8.5	Scaling to Very Large Problems . . . . .	128
8.6	Designer Insight . . . . .	131
<b>9</b>	<b>Conclusions</b>	<b>132</b>
9.1	Hierarchical Transaction Solutions . . . . .	133
9.2	Open Problems . . . . .	135
	<b>Bibliography</b>	<b>137</b>
<b>A</b>	<b>HTL Grammar</b>	<b>152</b>
<b>B</b>	<b>FFT and MSP430 Code Listing</b>	<b>158</b>
B.1	FFT HTL Code Listing . . . . .	158
B.2	MSP430 Code Listing . . . . .	159
<b>C</b>	<b>Tables of Matrix Multiplication Clustering</b>	<b>177</b>
C.1	Matrix Multiplication Size Sweep Data . . . . .	177
C.2	Software-Pipelining Data . . . . .	179

<b>D</b>	<b>Tables of FFT Clustering</b>	<b>181</b>
D.1	FFT Size Sweep Data . . . . .	181
<b>E</b>	<b>Tables of Large Pipelined DSP Example</b>	<b>182</b>

# List of Figures

3.1	A small hierarchical transaction design, annotated with possible variable values from a single execution. Each transaction shows variables that are read-in on the left, and variables and tokens committed on the right. The PARENT transaction owns variables $w$ , $x$ , and $y$ . When each of its child transactions begins, they make a local copy of these variables. Transaction B owns a variable called $z$ . Tokens are shown in italicized underlined text in the commit lists. Transaction C illustrates hierarchical token passing – tokens may only pass through their parent to reach higher transactions, following the same commit rules as data. Transaction C1 creates a token $tC1$ which is passed to C before finally being passed to D. . . . .	32
3.2	(a) FORK nodes replicate tokens when multiple transactions are guarded by the same token. (b) JOIN nodes wait for all input tokens to arrive before generating its output token. (c) SELECT nodes wait for any input token, discarding the remainders. . . . .	36
3.3	The same transactions from fig. 3.1 shown executing in different orders. As is demonstrated, the internal workings of transactions B & C do not need to be included. They are abstracted along the transaction boundaries. This idea is crucial to bounded concurrency analysis. . . .	38
4.1	Example of token-guarded hierarchical rule language used to specify transactions. This code describes fig. 3.1. . . . .	45
4.2	Rule tree traversal order – it dives into the child rules first, visiting them in topological order based on their dependency. This guarantees that by the time a rule is visited, all of its predecessors have already been visited. . . . .	61
4.3	Serial rules with local constant values . . . . .	64
4.4	Constant inference demonstrating rule-level parallel writes. . . . .	64

4.5	AST-level constant value inference – assume that the rule is provided $x$ with a constant value of <code>Int(3)</code> . The AST walker visits each node hierarchically and returns an evaluated result for the sub-tree. If the subtree is not constant (dynamic), then it returns a <code>NULL</code> value. . .	65
4.6	Constant inference for “if” statement example . . . . .	66
5.1	Illustration of execution semantics between sequential and concurrent iterators. . . . .	73
5.2	Built-in iterators provided to allow FFT indexing . . . . .	76
5.3	Code listing of FFT with Iterators. Each iteration is a new transaction. The double-pipe operator composes parallel iterations – elements are selected from the iterators specified and passed to the iteration transaction at the same time. . . . .	77
5.4	FFT indexing achieved through iterators . . . . .	78
6.1	Centralized control to determine parent transaction termination .	80
6.2	Centralized control with synthesized logic to determine parent closure. . . . .	81
6.3	Distributed control using counter tokens to implement synthesized closure logic. . . . .	81
6.4	Constructing the condition under which <code>Parent</code> can be closed, demonstrating how conditional tokens may terminate paths and must be accounted for. . . . .	82
6.5	A trace of the closure algorithm . . . . .	85
6.6	Possible concurrent transactions captured in sets. Every covered set is a strict subset of one of the minimal sets. Minimal sets are used for CCR analysis, while the both set types are used in race condition detection (if they commit to the same variables). . . . .	86
6.7	Mutual concurrency scaling with different hierarchy depth. “A” indicates the range for ANTP – the average number of transactions per parent. “A(0,50)” means hierarchies with ANTP between 0 and 50. . .	90
6.8	Mutual concurrency set construction runtime. . . . .	91
6.9	Race condition detection scaling. . . . .	91
6.10	Hierarchical transactions to pure function example. . . . .	94
6.11	Hierarchical Transactions to CDFG Example. Solid lines are data edges. Dotted lines are control edges. . . . .	98
8.1	Left: System point-to-point architectures with 1, 2, and 4 accelerators. Right: Accelerator without and with scratchpad memory (SPM)	112
8.2	Illustration of clustering that can induce cycles . . . . .	113

8.3	Internal architecture for peripheral. The bus provides initial operands and the program. A controller executes this program and uses the local operand block RAM (BRAM) to store intermediate operations. After the program has completed, the controller initiates a transfer to the DMA controller while simultaneously asserting an interrupt for the main CPU. When the DMA is configured in scatter-gather mode, the next set of operations arrives automatically, based on an internal linked list of data copying blocks. The peripheral on the right adds a local scratchpad memory to provide local, higher utility access to operand data. . . . .	115
8.4	Scheduler-driven clustering of FFT with corresponding cluster graph and system-level schedule for FFT . . . . .	118
8.5	FFT total schedule length (including bus transfers) versus size of BRAM for a 2-accelerator architecture. . . . .	122
8.6	Heuristic runtime scaling with increasing node counts on FFT instances. . . . .	122
8.7	For fixed BRAM size, both FFTs of size 1K and 256 exhibited the same shape across different peripheral accelerator configurations. . . .	123
8.8	Across different BRAM sizes, the SPM size was varied. Clearly, there is little to no improvement with larger BRAM. This correlates to utility limits stemming from a single port constraint. . . . .	124
8.9	Matrix multiply total schedule length versus BRAM size constraint for 2-accelerator architecture. . . . .	125
8.10	Matrix multiplication (of a 14x16 matrix with a 16x12 matrix) performance versus software pipeline depth & number of accelerators. It is interesting to note the trade-off between performance and device area. The jump for high-depth software pipelined designs shows a Pareto point that trades throughput for area. . . . .	126
8.11	Scaling for complex DSP application illustrates the heuristics ability to preserves near-linear scalability for a variety of design shapes. . .	127
8.12	Algorithms chained together to form a complex DSP demonstration.	128
8.13	For each application, the utility represents the ratio of the used versus idle cycles in the arithmetic pipeline. As the BRAM size is varied, the utility remains relatively constant. Introducing a small scratchpad immediately increases utility; scratchpad size has a much greater impact on performance than BRAM size does. . . . .	129
8.14	Visualization of scratchpad memory (SPM) and arithmetic pipeline utility for the same selected clusters of an FFT1024. The two are highly correlated: SPM size correlates strongly with higher performance, since fast access to operands allows the pipeline to remain busy. . . . .	130

8.15 Heuristic runtime up to millions of nodes . . . . . 131

# List of Acronyms

LT	Latency Tolerant/Tolerance
RTL	Register Transfer Logic
FPGA	Field-Programmable Gate Array
HTL	Hierarchical Transaction Language
HTSS	Hierarchical Transaction Simulator and Synthesizer
SoC	System-on-a-Chip
RSoC	Reconfigurable System-on-a-Chip
ASIC	Application-Specific Integrated Circuit
CPU	Central Processing Unit
GPGPU	General Purpose Graphics Processing Unit
DSP	Digital Signal Processor
ABI	Application Binary Interface
RAM	Random Access Memory
BRAM	Block RAM
CDFG	Control/Data-flow Graph
TLM	Transaction-Level Modeling
KPN	Kahn Process Network
AST	Abstract Syntax Tree



## Acknowledgements

We thank the National Science Foundation for their generous funding. We also thank Intel, along with the Silicon Research Corporation, through whom we received custom funding into latency tolerant synthesis (the foundation of this work).

# Chapter 1

## Introduction

Heterogeneous hardware/software cosynthesis is the automated binding, allocation, and scheduling of an application onto hardware and software components. The target architecture spans the spectrum across arithmetic units, microprocessors, memory hierarchies/allocations, and the myriad bus/communication interfaces that allow them to execute cooperatively. This dissertation introduces the *hierarchical transactional semantic*, an abstract application specification model designed from the ground up to target cosynthesis in a way that balances high-level behavior abstraction with high performance synthesis. This balance is achieved through a novel hierarchical data/control encapsulation semantic, encouraging architectural exploration through tool-accessible flexibility in how state and execution are realized. With any abstract specification model comes the risk of imposing performance-hindering constraints, such as handshaking or tight synchronization mechanisms that prevent exploitation of parallel performance. The model, however, enables scalable synthesis, bounded analysis, clean and concise design specification, and verification without sacrificing performance. Finally, the management of memory and memory capacity is crucial to meeting high perfor-

mance implementations. The presented semantics allow direct control over data motion, capturing cost models that genuinely reflect their underlying architecture.

The evolution of computationally diverse heterogeneous platforms has opened new opportunities to meet high performance constraints across remarkably diverse architectures. Device advances have shaped the system-on-a-chip (SoC) landscape, including field-programmable gate arrays (FPGAs), hybrid FGPAs, full custom integrated chips, and commercial fixed-architecture platforms. The common thread across these platforms is the integration of complex distributed memory architectures, including caching hierarchies and local scratchpad memories (SPMs); in fact, the majority of silicon real estate is dedicated to memory and caching resources. Conventional automated approaches focus on functional components, specifically operations and arithmetic resource binding. Management of state and caching resources, however, are often treated as a secondary effect. In this work, clear representation and management of global state ensures that operational units are adequately used, and becomes a primary goal of the synthesis strategy. The importance of this effort grows as application memory demands scale beyond the capacity of local resources. Making efficient use of available data resources is an enormous ongoing challenge, and calls for a fundamental rethinking of the computational and memory models.

This research introduces a novel specification model with unique underlying data and execution semantics designed to enable cosynthesis across varying computational domains without sacrificing performance. Its focus is on application specification, restricting designer behavior while encouraging explicit and clear expression of designer intent. At its core is the hierarchical transactional model, a

formal, abstract model of computation that captures state and execution common across heterogeneous semantic and execution models. The model enables structured cosynthesis that is resilient to shifting platforms and varying constraints, all the while leveraging a unique data/execution encapsulation framework to guarantee scalable analysis. At the front end is a practical, understandable specification language that encourages concise design of complex applications.

## **1.1 From Codesign to Cosynthesis**

The impetus behind software/hardware co-design is simple: software models are sufficiently abstracted from hardware, allowing easy adaptation to new architectures. A stringent set of abstractions shield software from changes in e.g. caching layout, protocol interfacing, and physical memory constraints, none of which affect correct execution. Comprehensive tool suites and well-honed design practices allow software to be practically scalable and are key to faster time-to-market.

In addition to easy adaptation, co-design is a mature field with a wealth of research, industry support, and tools to ameliorate challenges that may arise during software development. Device vendors maintain stable ABIs to assist development on shifting platforms, encouraging incremental design coinciding with platform upgrades. Co-simulation packages simplify validation and integrate well with existing engineering methodologies, facilitating short design iterations and quick exposure of otherwise-evasive bugs.

When software can no longer meet application performance demands (be it high throughput, low latency, and/or meeting real-time deadlines), designers employ hardware accelerators. Manually converting software into hardware is practical for small-to-medium applications and often involves significant algorithm restructuring to better leverage available concurrency. Mixing concurrent software and hardware, however, can quickly lead to a litany of component integration challenges. Reaching high performance, high utility designs involves significant engineering effort to navigate around concurrency bugs, resource arbitration complexity, and mixed protocol integration. At the same time, there are no global strategies for maximizing use of distributed, heterogeneous memories. The reality of state-of-the-art co-design exposes a gap between potential performance versus practicable design methods. Automated cosynthesis

### **1.1.1 The Case for Cosynthesis**

In the most general sense, cosynthesis optimizes applications across varying computational domains. The most common instance refers to embedded system synthesis: the automatic creation of hardware accelerators interacting with a larger software application. At the very minimum, it includes scheduling and binding of bus interfaces and memories, along with synchronization infrastructure required to make it work coherently.

Specification-to-silicon cosynthesis holds tremendous potential to provide a fundamentally robust design methodology that not only adapts to shifting platforms, but exploits available resources to reach unprecedented performance. Its benefits are across the board: improved time-to-market, rapid development itera-

tions to determine system costs early in the design process, and effective architectural level optimization. Such a framework would allow designers to exploit novel memory architectures and complex intrachip networks, all the while equipping them with the tools they need to validate and verify otherwise difficult-to-debug concurrent applications.

### **1.1.2 The State of the Art**

In reality, the heterogeneous computing landscape is rife with scaling challenges, ill-suited specifications that are incompatible with the underlying hardware, concurrency bugs, and poorly modeled system costs. Available cosynthesis tools simply cannot cope with meeting difficult constraints against such a diverse design space, especially as applications scale up in size. One of the fundamental issues is a distinct lack of a unified model capable of bridging different computational domains together. Without a comprehensive representation model, there is strong reliance on graph-based approaches and software-to-RTL models. Scalable, practical synthesis is possible with an expressive specification language designed around system-level optimization, rather than adapted from existing approaches. A unified computation model can accommodate vastly different data and execution models to exploit varying degrees of potential parallelism. It requires capture of dominant system costs and a high degree of flexibility in realizing behaviors across different classes of components.

### **1.1.2.1 Exposing and Modeling Dominant System Costs**

When profiling applications, designers rely heavily on experience, as there are no straightforward ways to intuit a system's cost without comprehensive simulation and implementation. Even with rich modeling tools, the true costs of a system may not become apparent until the application is executing in silicon.

In current generation heterogeneous computers, application performance is dominated by the motion and storage of information. Computational pipelines vastly outpace memory interface speeds, often by several orders of magnitude. Hierarchical transactions were designed to expose and codify real system costs, particularly with respect to data motion. They allow direct capture and management of data motion costs to reflect modern architectural realities.

### **1.1.2.2 A Symbiotic Development Relationship**

Robust design methods are clearly advantageous to designers. There is another key benefit: it has the potential to liberate commercial vendors and IC manufacturers from legacy interfaces. When a company releases an SoC product, they are beholden to uphold the same or compatible ABI for further versions of their product. The first iteration effectively sets in stone core architectural features that define its platform. Pressure to preserve these configurations comes from both sides: significant effort goes into developing compilers, simulators, libraries, etc. and vendors are reticent to redesign their tool chain. On the other side, customers demand backwards compatibility to avoid the risky task of reimplementing their application.

For example, a first iteration SoC may contain a centralized, cache-coherent RAM. In the next design iteration, newer research or device technology could make available e.g. distributed, lower power memories through crossbars. However, neither side is incentivized to adopt the technology because of rigidly coupled specifications paired with long, cumbersome design and verification times. Worse, customers' applications are tightly coupled to the platform's original architecture; leveraging the next generation's architecture may require a rewrite.

## **1.2 Contributions**

The hierarchical transaction computational model lays groundwork for a unified semantic data and execution model. It codifies high-level application behavior through a carefully constructed semantic and syntactic model designed to ensure robust design methodology. Transactional data semantics guarantee verifiable behavior of latency-tolerant concurrent tasks. The notion of computational and state mobility supports maximal exploitation of parallelism – at their core, hierarchical transactions localize all state and control. This encapsulation enables use of hierarchy that is scalable to very large designs. As a result, access to the optimization space is not hindered by complexity in analyzing a specification.

At the front end is a novel specification language to directly represent hierarchical transactions. It focuses designer intent through specific limitations in how state is accessed. Designers are empowered with tools to directly identify and address concurrency bugs. The language is structured with synthesis in mind – it provides methods of expression that are confined to actions commensurate with



optimization. Designers express families of valid executions in a minimal format through high-level dependencies, type systems, and computational relationships. Low-level resources such as computational pipelines, protocols, and memories appear as interchangeable resources.

A corresponding compiler enables rapid behavioral simulations including fast identification of race conditions while providing direct paths to high-utility synthesis. Through a unique iterator specification, a compiler generates bounded-lifetime dataflow representations well suited for high performance computation. Often, in an embedded system, heterogeneity arises from the use of highly concurrent arithmetic pipelines. The primary bottleneck becomes the management and allocation of local state. This is addressed with a series of clustering heuristics that exploit controlled variable lifetime and high-flexibility transactional tasks to make efficient use of distributed memories and computational pipelines.

### 1.2.1 Computational and State Mobility

Traditional scheduling contains a notion of mobility for a given node/task – this describes its relative ability to “shift” in time, essentially describing its scheduling flexibility. Hierarchical transactions enforce a notion of computational and state mobility. This extends the concept of operational mobility to include a task’s overall behavior, its intermediate and long-term storage, and its timing characteristics, especially across varying memory granularities.

There are three dimensions to the mobility of a behavior: (1) computational mobility describes flexibility of *the domain* that can implement the behavior; (2) state mobility describes *where* it may be realized, essentially representing how

tightly coupled the operations are to their associated storage; and (3) scheduling mobility describes *when* a task may begin or end. The tighter any of the three properties are constrained, the less opportunity there is to reach a feasible architectural implementation. Contrawise, greater flexibility across all three enables a design space amenable to architectural, system-wide optimization.

Computational mobility can only occur if the application specification is sufficiently abstract, e.g. it is not bound to any particular computation unit. State mobility requires that any computation be localized to its state – if a task needs to be done, both its state *and* its computation/control is treated as a discrete, mobile object. Scheduling mobility requires true timing decoupling through intrinsically latency tolerant design (intrinsically, as opposed to explicit, requires a fundamental guarantee *a priori* and a natively latency tolerant input specification).

Hierarchical transactions enforce true computational & state mobility through hierarchical encapsulation of state and control. All of the information a given behavior needs is encapsulated into a transaction, and its read/write interactions occur on well-defined transaction boundaries.

### 1.3 Overview

This research lays groundwork for a novel specification approach, evaluating its potential as a complete cosynthesis solution. As such, it is not a comprehensive exploration of the model. Instead, this dissertation details studies that exercise different aspects of the model with four goals in mind: (1) encouraging clear, concise application specification that communicates designer intent, (2) providing prac-

tical design tools to address correctness, (3) representing real control-dominated applications, and (4) enabling automated paths to efficient high-performance realizations.

First, Chapter 2 briefly surveys specification and representation models in cosynthesis. Chapter 3 introduces hierarchical transactions, including the novel concept of state and control mobility through hierarchical encapsulation.

To support clear and concise expression of the semantic model, a novel guarded rule-based language is presented in 4. It efficiently captures complex control as well as arithmetic-heavy applications. A full featured compiler and simulator provide front-end features to guide designs and discover correctness errors. Chapter 6 presents design analysis methods that demonstrate feasibly scalable isolation of race conditions. Additionally, algorithms are provided that directly translate selective portions of an application into control/data-flow graphs, outlining how hierarchical transactions can map into different existing semantics.

Real-world heterogeneous systems exhibit a mix of complex control and high-performance computation demands. The final two goals represent either end of this spectrum. Chapter 7 discusses implementation of a microprocessor, describing control specification as well as practical race condition detection. Finally, Chapter 9 presents a high-performance cosynthesis methodology targeting hardware acceleration of Fast Fourier Transform (FFT), matrix multiplication, and image convolution. The presented near-linear clustering and scheduling heuristic scales up to million-node problem sizes.

## Chapter 2

# State of the Field

Cosynthesis (also called embedded system level [ESL] synthesis) is part of a broader co-design research field including hardware/software partitioning, software-to-RTL, and co-simulation. Each of these sub-fields have developed a diverse range of heuristic and exact solutions, many of which are surveyed in [86, 23, 33, 88, 87, 64, 71, 80, 84, 3]. Approaches range over a variety of language, semantic model, and domain & application-specific solutions. It is important to note that there is no single definition of cosynthesis – instead, automation is used to varying degrees depending on the problem setup, the target environment, and the assumptions underlying design flow. For instance, some approaches view cosynthesis as an extension to cosimulation: models are generated at a high level, then manually partitioned and synthesized into their respective domains. Others take a single-specification format and perform full automation down to silicon.

Despite a wide gamut of approaches, a unified solution has not yet emerged due simply to the sheer extent of the challenge – instead, a variety of methods have evolved to address specific architecture classes and problem scales. Unlike RTL, which has a relatively mature Boolean logic-based foundation, there are

as many variations of the problem setup as there are solutions. This not only complicates methodology comparison, but there are no straightforward ways of comparing generated design performance. Common benchmarks (such as JPEG and MPEG encoding/decoding) provide a similar basis for initial specification; however, divergence in optimization criteria renders any comparison uneven. The broad scope has prompted taxonomy classification suggestions [80]. The magnitude and breadth of computation, data management, and myriad interfaces mean that the heterogeneous design space is difficult to automatically traverse and particularly prone to scaling difficulties.

This chapter will discuss the common used models, particularly input specification format/underlying semantic models, and how that affects automation methodology. It will extrapolate fundamental assumptions that comprise both problem setup and results. The primary differentiators in the proposed hierarchical transactional model are: built-in scalability, data/control mobility in the input specification, and direct capture of memory capacity. These factors will be the basis for comparison against existing approaches.

This chapter first provides a general discussion on existing system representation formats (particularly graphs), introduces challenges arising from addressing/indexing, and is followed by an overview of existing work in the above sub-fields.

## 2.1 Behavior and State Representation Models

The single most common method of representing heterogeneous-targeted applications is the data-flow graph. Representation granularity ranges from fine grained operation-centric formats to coarse task-scale graphs aimed at abstracting lower-level detail. Hierarchy is occasionally used to target scalability[15, 26, 67, 75], often in the form of control hierarchy[56] (as opposed to state hierarchy). While control hierarchy simplifies reasoning of application flow, it does not ease handling of memory capacity constraints.

### 2.1.1 Early Computing Models

Early computing relied on an execution model based on the physical realities of its era. Both processors and volatile memories were of relatively similar speed. Large, nonvolatile storage were approximately an order of magnitude slower, but ultimately, arithmetic computing dominated costs in high performance applications. These constraints shaped the entire philosophy behind computing design, particularly in software and at the hardware/software boundary.

Much of the early technology constraints are still visible today in co-design/co-synthesis. The idea that hardware design centers around operations is a pervasive one, and has driven the field of high level synthesis towards operation-centric optimizations. As transistor technology has improved (through miniaturization), the performance gap between arithmetic operators and memory access speeds has grown tremendously. A significant portion of architectural engineering revolves around mitigating the gap through caching strategies, prediction/look-ahead, la-

tency hiding paired with deep pipelines, deep memory hierarchies, and a variety of manual memory localization tricks (i.e. design philosophies that attempt to keep operands as physically close to their arithmetic logic).

As a result, dominant costs in high performance software is the motion of data. General-purpose graphics processor (GPGPU) pipelines are a prime example: they accelerate high operational computations, but are largely useful only when computational requirements far exceed data requirements. A significant portion of accelerated applications runtime is dedicated to moving information to and from the memory attached to the GPGPU – in fact, standard design practices are centered around overlapping this transfer with computations reach maximum throughput.

### **2.1.2 Moving Towards Novel Models**

Data-flow graph techniques straddle the technological boundary between operation-dominant and data motion-dominant systems. Graphs are a straightforward representation of operations, although they do not explicitly represent state – instead information is captured in the dependencies between operations (i.e. graph edges). As dominant system costs shift, so should representation models. An overview of data-flow graphs follow, along with a discussion on why additional control complicates verification in the codesign space.

### 2.1.3 Data-flow and Task Graph

A data-flow graph is a directed graph consisting of vertices/nodes representing behavior, often arithmetic operations. Directed edges represent information passing from one node to another, and therefore induce a dependency between the nodes. Graphs comprise the majority of existing research and commercial tools as they are easy to reason about and lend themselves to many well-understood heuristics. Adapting meta-heuristics such as simulated annealing and genetic algorithms is often straightforward[84]. Further, graphs can be directly scheduled[4, 16, 44, 91], as they contain the minimum dependency information required to apply any of the well-known scheduling algorithms.

Data motion is along the edges, between operations. Initially, edges are not bound to any specific resource element; instead, a cosynthesis solution maps these edges to either software registers, hardware latches, and/or bus transfers. When partitioning an application into hardware and software domains, data motion costs are measured by observing the amount of information that flows across a partition's boundary – this eventually becomes the hardware/software communication.

Data-flow is designed to model a specific class of application and thus avoids the issue of arbitration. For control/data-flow graphs, if they *do* include arbitration nodes, formally verifying correct behavior becomes very difficult – deadlock is common when concurrent paths arbitrate resources over varying latencies[18, 61, 60, 11, 24]. When multiple elements need to share a single resource, arbitration becomes the synthesis tool's responsibility, inducing performance-limiting synchronization mechanisms. When these mechanisms show up in the cost model,



they effectively pre-partition the graph (since the alternative mapping bears a prohibitively high cost).

Hierarchical transactions, on the other hand, are an abstraction layer above data-flow. They capture more information and specify very large families of potential mappings and executions. Interaction between shared state resources are explicit – there are no implicit arbitration points. Instead, any potential reordering of shared data writes are passed to the designer to resolve, thus avoiding race condition situations. Better yet, there are direct paths to data-flow graphs. A method in chapter 9 selects one of the families of valid execution and localizes data along the edges. In situations where data-flow may not be appropriate, the synthesis tool may leverage existing arbitration techniques to ensure correct behavior. For example, control-heavy sections of an application well-suited for software may use built-in atomic instructions to arbitrate shared data.

#### **2.1.4 Latency Tolerance**

One of the aims of our model is to leverage existing research that is compatible with presented semantics. Domain-specific models can be appropriately targeted depending on system constraints to make maximal use of available platforms. Therefore, transactions leverage existing latency tolerance technology [13, 21, 22, 49] to manage control, accurately reflect the way heterogeneous components interact, and apply existing verification techniques to ease designer burden.

## 2.1.5 Transactions, TLM, and Transactors

### 2.1.5.1 Transaction Level Modeling

Transaction Level Modeling (TLM) is a popular method of improving simulation speed, and therefore improving design quality and time-to-market. The primary “transaction” in TLM is largely focused on simplified data motion isolated from bus semantics. Rather than simulating complex concurrent state machines, they simulate black boxes emulating those machines with dramatically lower computational requirements. TLM was introduced as a way of performing sensible design exploration and validation of complex systems [12]. Recent research has emerged in directly synthesizing TLM designs, particularly individual parts of the system (e.g. bus communication [72], emulation/verification/simulation [62], and task-centric solutions[57]).

### 2.1.5.2 Synthesizable TLM

Recent pragmatic system synthesis approaches transform SystemC TLM 2.0 models into Kahn Process Networks (KPNs), assuming the inputs follow certain bounded looping behavior[38, 65, 53]. Since the approach begins with a C-based specification, state and control must be manually preallocated into smaller sub-tasks to fit into their target model (task partitioning). As a method of codifying interactions, this approach has proved capable in full-stack specification to silicon, in large part due to guarantees in the KPN model. Unfortunately, not all applications in this space can be represented with KPN, and thus the application

space is limited. Further, there were few scalability guarantees discussed in their respect papers.

### **2.1.5.3 Nested Transactions and Software Transactional Memories**

While the hierarchical transactional model differs in critical ways from current TLM work, it does share semantics with nested transactions applied to transactional software memories and database systems. These models have proved to be sound and complete, wrapping data and control [2, 1]. The same challenges facing database coherency appear in heterogeneous systems, for many of the same reasons – primarily, databases are distributed to share a large workload over multiple computational units. Since these units (database server nodes) each run at their own pace, they cannot be statically scheduled. All of the information must remain coherent over a complex data network. Similarly, cosynthesis must ensure correct data exchange over buses (rather than ethernet) using arithmetic accelerators (rather than database nodes). Transactional memories [37, 50, 43] are similar models addressing the issue of data coherence.

This work differs in that it includes functionality in the transactions rather than just state. Further, latency tolerance is explicitly specified via a rich token-based abstraction, thus concisely describing functional dependence. While the problem setup may share similarities, the heterogeneous design space exhibits dramatically different costs and must be tuned accordingly.

#### 2.1.5.4 Transactors

Asasnovic's work in [7] transactors is another closely related semantic; however, in their approach, communication is handled through explicit FIFO channels between transactors, and follows a BlueSpec-like model. Further, they did not exploit hierarchy. Work by Belarin [9] uses the transactor nomenclature, but focuses on bridging high-level and low-level models, eventually using Hierarchical Finite State Machines (HFSSMs) for code generation. The latter model puts no bounds on control, and can run into many of the same problems that traditional control flow graphs suffer.

#### 2.1.6 Hardware/software Partitioning

Efficient hardware/software partitioning is a well-researched topic [86, 83, 30, 51, 41, 42, 40, 52], leveraging popular heuristics [8] including simulated annealing (SA) [30], genetic/evolutionary algorithms (GA) [76, 6, 28, 84, 45, 75], dynamic [60, 66] and linear programming [68, 6]. The myriad approaches are surveyed in [84].

Partitioning is generally grouped under the co-design umbrella and involves deciding which functional elements from an input specification should be implemented on software versus hardware targets. Input specifications are relatively abstract functional descriptions in order to facilitate this flexibility. Heterogeneous architectural targets are either assumed to be capable of implementing all functions, or are categorized into groups.

Input specifications are almost universally represented in the form of control/-data graphs. The solutions assume a one-to-one mapping between input graph/-tasks and the target architecture, or they construct mapping data structures to represent all valid architectural maps. The latter can grow exponentially. As a result, they are not amenable to large designs that exceed locally available hardware resources.

### 2.1.7 An Overview of Cosynthesis Models

Early work by [34, 35, 89, 17, 79] established the basis for future cosynthesis work. These approaches universally use tasks graphs (with some applying hierarchy for control compactness[15]). Variations include timing annotated and periodic task graphs [28, 25]. Multi-mode approaches [55, 70] focus on mapping task graph sets according to different modes of operation.

The Hierarchical extended Task Graph (HeTG) introduced in [59] extends basic task graphs with control nodes, specifically fork, join, and select nodes. Their primary goal is to allow powerful control that is compatible with scheduling. Further, they encapsulate behavior into hierarchical nodes, allowing coalescing of control logic (i.e. a hierarchical task is responsible for the control overhead of its children). This work applies similar techniques, but pushes data encapsulation to the forefront.

Chinook [17] accepts an HDL-like input specification, adopting RTL-style data and control semantics; that is, data and control are not constrained and therefore the design do not express state & control mobility.

The Daedalus system [82, 69] accepts KPN-based inputs to perform full system synthesis, taking advantage of accurate system modeling to correctly model and optimize the system accordingly. They benefit from KPN’s guaranteed boundedness and straightforward data exchange; however, not all applications are well-suited for KPN, as it precludes any application that requires control.

Hierarchy has been used to different effect in cosynthesis models. For instance, [39] leverages hierarchy to describe alternative realizations of the same coarse-grained task – this simplifies the search space and improves convergence.

The PeaCE [36] multimedia research included full-stack cosynthesis based on the Ptolemy[63] mixed computation modeling system. It restricts Ptolemy to two models: a “piggybacked” synchronous data flow (SDF) and an extended “flexible” finite state machine (fFSM)[56]. Piggybacked SDF models are introduced control tokens, much in the same way [59] extended task graphs. Without formal deadlock resolution, traversing this design space can be difficult and cumbersome. The fFSM is particularly interesting because it constrains state machine transitions along hierarchical boundaries, thus confining control scope; this goal is shared by hierarchical transactions and motivates the encapsulated token model.

#### **2.1.7.1 Magellan**

The MAGELLAN [15] project shares many philosophical goals as this research, and provides a complete cosynthesis package. At its core, it iteratively maps hierarchical control/data-flow graphs onto a heterogeneous architecture, decoupling specification from target. Its input semantic uses hierarchy primarily to coalesce control complexity, thus avoiding the need to identify control symmetry. It fur-

ther leverages hierarchy to make multi-grained moves during optimization. The separate graphs – application and architecture – are constructed into a new graph representing groups of possible architectural maps. A heuristic iterates over this structure and incrementally improves latency and area.

The demonstration JPEG application is relatively small, although a large part of their compaction arises from hierarchy. The presented data is notably fast (on the order of 11 seconds to optimize the design) – however, there is no discussion on how the approach scales. For a design on the order of tens or hundreds of thousands of nodes, it is clear that the architectural mapping alone would render the approach infeasible. Hierarchy is an option to keep this in check, but it is not clear that a large, deep hierarchy will converge. Their optimization heuristic requires the ability to make multiple, multi-scale moves; if each step is too computationally or space intensive, then the heuristic simply would not get the opportunity to try many system configurations.

#### **2.1.7.2 Metropolis**

Metropolis[10] similarly shares the same goals as this research. Their approach is built on concurrent communicating processes (CCP)[46], a well-researched, clearly defined formal model for concurrent tasks. CCP evolved from message passing where deadlock/liveness issues were common[5] – thus, a heterogeneous application model based on CCP benefits from this research. Metropolis also represents an abstract model (philosophically similar to hierarchical transactions) and is clearly capable of representing lower level architectural models. While CCP is an abstraction well suited for representing complex control and semantically sim-

ilar applications, it does not directly model data/intermediate operand storage. As such, its data modeling is limited to the information captured through message passing interfaces. In situations where the task contains persistent state, its interactions are treated as abstract behaviors rather than explicitly codified state modification.

Its quasi-scheduling technique is amenable to hierarchical transactions through two paths: first, by converting transactions into Petri nets (similarly to the method used for data-flow projection), Metropolis' methods can be applied directly. When constructing this Petri net, Metropolis effectively selects a specific execution path through its internal mapping network before passing this to the scheduler to determine timing. An alternative transaction strategy can select one of the valid families of execution and apply the techniques without the Petri net intermediary. The primary benefit would be leveraging Metropolis' communication overhead optimization.

### **2.1.8 Bluespec**

Bluespec is an operation-centric rule-based guarded action language. It rides on a FIFO-based communication network that is ultimately realized through handshaking (ready and stall signals). Its power is in its ability to meld high-level functional type semantics with low-level RTL-style semantics. Designers reach fast design convergence, quickly determining the true costs of the system. The methodology is compatible with RTL design, and thus makes the transition smoother.



While low-level signaling and clock-scale design are easier to use, they also leave the Bluespec compiler with few options when realizing the design. Scheduling is relegated to the limited freedom the designer allows (if they, for instance, explicitly design with several clock cycles of latency tolerance in mind).

Despite being natively latency tolerant, the compiler ultimately schedules the design by packing as many rules into a single cycle as it can. It is the designer's responsibility to ensure timing closure by running synthesis and then manually cross correlating the violating paths to the original specification. They insert pragma statements manually rescheduling rules causing timing violations. The Bluespec compiler makes it remarkably simple to institute necessary scheduling and resource allocation changes due to its robust type and module instantiation/-parameterization system. The underlying FIFO model allows a certain degree of separation from clock timing where hard bounds are unneeded.

Unless the application is very carefully planned with the compiler's code generator in mind, the resulting RTL can contain tightly coupled components via its handshaking control signals. These wires scale poorly with the size of the application, making timing closure increasingly difficult with scale.

## **2.2 Software-to-RTL**

The class of C-to-RTL/Software-to-RTL research and commercial products have reached maturity and (for applications that suit their assumptions) commercial viability. These tools directly address hardware acceleration of selected components from a sequential procedural application[47, 34, 27, 31, 19]. Geared

towards high-arithmetic algorithms, their primary task extracts maximal concurrency from a sequential specification through an assortment of advanced loop and pointer analysis heuristics[71, 14, 77]. They create data-flow graphs which are mapped into RTL components while their input/output interfaces are mapped onto buses.

### 2.2.1 Model Representation

As a result of adopting data-flow models, these approaches largely suffer from the same drawbacks that existing approaches have. While they do allow fast paths from software to hardware, ultimately, C is an ill-suited language for hardware[29].

**IP Reuse** IP reuse is touted as a driving force for using C-to-RTL. For applications already written and tested in C, the idea of simply applying a turn-key solution to existing code is immensely appealing. In the real world, this design flow does not pan. Fundamentally different assumptions in the sequential execution model yield diminishing returns in extracting concurrency from a sequential program[29].

Aside from the efficiency argument, C applications often require engineering effort to comply to the C-to-RTL tool's subset of C. RTL models are limited to the expression power of a finite state machine (FSM), and thus the tools can only accept applications that are isomorphic to FSMs. Further, almost every nontrivial C program uses dynamic heap and stack allocation; there are noteworthy heuristics that can aid this problem [85, 78] but must carefully avoid intractability. Thus, in the real world, existing IP must often be rewritten to allow the compiler

to generate static hardware. The code must be sanitized to remove architectural optimizations such as cache optimality.

## **2.3 Moving Towards Hierarchical Transactions**

A significant amount of research has addressed co-design and cosynthesis through approaches. While graphs are an excellent method of reasoning about operations in high-arithmetic applications, they are ill-suited for resolving complex control or data arbitration. It has become evident that a new model needs to address this issue while still allowing high-computational portions of an application to leverage existing work.

Hierarchical transactions can be targeted towards multiple semantic models, thus granting the benefit of data coherence over large-scale data sharing protocols (similarly to database systems), and yielding high performance through graph-based approaches where appropriate (leveraging advances in modern cosynthesis). The model has been carefully designed to allow a broad spectrum of synthesis techniques that are suitably adaptable to the often incompatible semantic and execution models that underpin real-world heterogeneous systems.

# Chapter 3

## Hierarchical Transactions

The hierarchical transactional semantic data and execution model is a novel approach to specifying complex designs across the control and data spectrum. The model supports a concept of state and control encapsulation, enforcing local behavior throughout an application. Through careful design of its execution semantics, the model leads to design analysis and synthesis solutions that are both practicable and scalable. It brings state capture to the forefront, ensuring access to automated exploration of different memory management architectures.

### 3.1 Abstraction

A semantic data and execution model captures either abstract behavior or reflects a specific architecture. The advantage to the former is a clear delineation between high-level application behavior and its target platform. The latter exposes important cost metrics critical to efficient optimization. Historically, common practical models have attempted to balance both model classes. In RTL, the execution model is inherently concurrent and can become unintuitive as an

application grows; complexity is typically managed through finite state machines that abstract complex concurrent interactions and enable sequenced behavior and easy-to-understand semantics. On the other side, the C programming language maintains a primarily architecture-agnostic specification, but contains inline assembly, pointer arithmetic, and e.g. volatile type classification to reach low-level architectural optimizations.

Hierarchical transactions (HT) are a purely abstract model – however, what sets them apart is they are designed from the ground-up to adapt to directly modeled architectures commonly found in the heterogeneous computing space. More importantly, HT enables better use of existing semantic and data models through computational and state mobility – it specifies a larger class of configurations that provide multiple mapping paths to existing hardware or software models. For example, there are a variety of options for constructing a synthesis path from HT and RTL, depending on the particular state and computational constraints for the target architecture.

## 3.2 Challenges in Cosynthesis

Hierarchical transactions directly address cosynthesis models through a combination of features that unify heterogeneous models into a codified, analyzable, and scalable manifold.

**Concurrency** One of the primary benefits for shifting computation into hardware (besides potential power savings) is its tremendous concurrency/parallelism

potential. To reach this potential, the model natively supports and encourages heavily concurrent behavior. It provides direct paths for mapping RTL, DSPs, and GPUs (all of which enable high degrees of concurrency), all the while ameliorating common concurrency problems through a race condition/deadlock reporting mechanism.

**Latency Tolerant** Software, FPGA RTL, DSPs, and GPUs all exhibit vastly different timing characteristics. To enable synthesis across these domains, all of the specified behavior in an application is required to be latency tolerant. Traditionally, dynamic timing flexibility had the drawback of increased overheads and performance penalties. However, this model is designed around the ability to optimize unnecessary dynamic latency tolerance in favor of static schedules based on the architectural optimization criteria. In essence, the compiler decides where to preserve dynamic latency tolerance based on its assessment of implementation costs. Latency minimization, therefore, is a synthesis constraint. From the designer's point of view, they need only specify correct gross ordering, rather than hard timing (which is relegated to resource models where hard timing is critical, e.g. bus or protocol timing).

**Transactional** The combination of concurrency and latency tolerance are key to model robustness. However, they also lead to difficult-to-find concurrency bugs, making verification cumbersome and time-consuming. The solution is to enforce all data interaction to be well-defined and analyzable along transactional events.

If the tool knows how and where data and control information are accessed, it is able to identify potential concurrency bugs very early in the design stage.

**Copying Semantic** A copying semantic gives each task the illusion that it has its own local copy of all data & relevant control state. Decoupling dependent tasks means synthesis tools can realize any part of the behavior in any domain. Encapsulated behavior further alleviates difficulties in implementing cross-domain control. It is an optimization opportunity that maximizes architectural search space: the synthesizer has full knowledge of data and control variable lifetime, and each transaction copy is a potential design decision that can easily be optimized out where unneeded.

**Hierarchical** Another consequence to concurrent, latency tolerant behavior is potential exponential growth when analyzing execution paths. In order to determine data operations that may lead to concurrency bugs, every possible path must be explored. Hierarchical design analysis alleviates this, especially with the combination of transactional data interaction and a copying semantic. Every subtask or group of transactions can be completely isolated from the rest of the design, dramatically limiting the number of exponential decision paths for well-partitioned input specifications. Pseudo-linear analysis is now possible since high-order polynomial or exponential growth on the local child network is eclipsed by the linear traversal of the hierarchy – i.e.  $2^n$  is insignificant for small  $n$ . Further, this type of hierarchy is amenable to optimization during synthesis: the overhead traditionally

associated with hierarchy is optimized away since that overhead is codified in the copying semantic.

**Controlled Array Access** Most, if not all, high-computational applications (e.g. signal processing) require the ability to traverse (multidimensional) arrays. Traditional specification languages provide arbitrary indexing into arrays which has historically made concurrency extraction very difficult, forcing tools to rely on heuristics and designer feedback to control array stride. Indexing also complicates accurate determination of variable lifetime. Hierarchical transactions provide an alternative to arbitrary indexing. Repetitive/looping array behavior is specified through well-defined, analyzable iterators to achieve the same specification flexibility as traditional looped code. The approach allows large arrays to coexist with the copying semantic – only the current iteration needs to be copied locally, and iterators grant information to the compilers about precisely which subsets will be copied.

From a specification clarity point of view, iterators express designer intent more concisely and accurately than arbitrary index functions. They signal to the synthesis tool precisely how data in the array is to be accessed.

## 3.3 Semantic Model

### 3.3.1 Hierarchical Transactions

The core component of the semantic model is the hierarchical transaction.



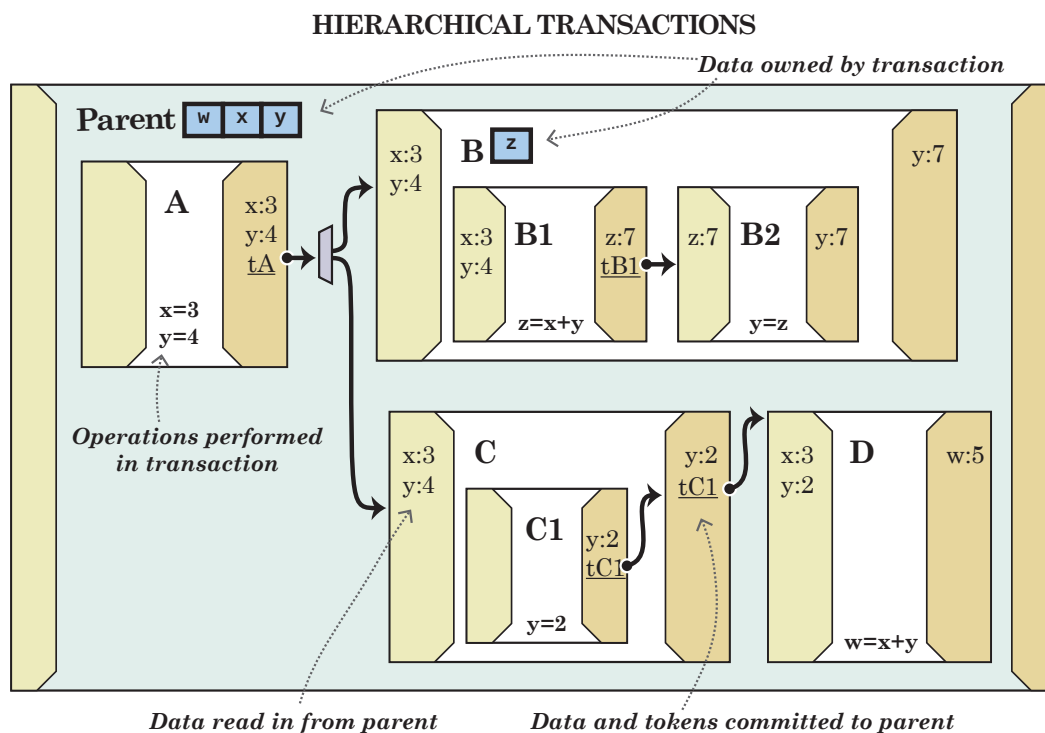

Figure 3.1: A small hierarchical transaction design, annotated with possible variable values from a single execution. Each transaction shows variables that are read-in on the left, and variables and tokens committed on the right. The PARENT transaction owns variables  $w$ ,  $x$ , and  $y$ . When each of its child transactions begins, they make a local copy of these variables. Transaction B owns a variable called  $z$ . Tokens are shown in italicized underlined text in the commit lists. Transaction C illustrates hierarchical token passing – tokens may only pass through their parent to reach higher transactions, following the same commit rules as data. Transaction C1 creates a token  $tC1$  which is passed to C before finally being passed to D.

**Definition 3.1.** An *action* is a set of one or more statements. Each statement may be an arithmetic operation, an assignment (state updating), conditional statements based on the local state, or token creation. Every action in the transaction executes atomically and concurrently. All reads and conditions are evaluated first, then all of the writes are performed independent of ordering.

**Definition 3.2.** A *transaction* consists of: a *guard*, local state, and either an action or an acyclic dependency graph of child transactions.

### 3.3.2 Overview

Every behavior in an application is described by transactions exhibiting well-defined start and end events. Data and control scope is strictly local – i.e. outside transactions may not modify or observe internal variables or control state. Transactions may contain child transactions arranged into a directed acyclic dependency graph, thus forming a hierarchy of transactions.

All transactions encapsulate behavior, data, and control within a strict local scope. When a child transaction begins, all of the data that it needs is copied from its parent. When it completes, the transaction may commit changes to its parent. Every transaction (subtree) can be viewed as a pure function, accepting input data from its parent and returning updated values. All of their data (owned and inherited) is local to its scope. This interaction occurs strictly between child and parent only – a grandchild cannot directly access its grandparent’s data; it must go through the intermediate transaction. It is important to note that the final implementation does not need to maintain this copying. Such a system

would incur large overhead. Instead, binding and scheduling determines low-level implementation while preserving the application's behavior.

An example design is shown in fig. 3.1. The figure illustrates both hierarchical encapsulation, data interactions on transaction boundaries, and hierarchical control token passing (described below). Both transactions **B** and **C** get their own copies of variables  $x$  and  $y$ . **B1**, the second child of **B**, reads the local value of  $y$  from its parent. Transaction **C1**, meanwhile, commits a new value of  $y$  to **C** before it finally gets committed to the parent.

### 3.3.3 Computational and State Mobility

The most significant element of hierarchical transactions is computational and state mobility. Every transaction strictly encapsulates all of its internal behavior through an abstract copying semantic that guarantees state is always local. These attributes ensure a high degree of mobility and flexibility when determining where to map architecturally. For instance, for a given transaction, if its parent exists in software while it is mapped onto a hardware accelerator, the copying mechanism becomes a bus transaction. If the same transaction remains in software, but is targeted towards a multicore implementation, then the copying manifests in a partitioning of the state. Rather than manage memory coherence, the synthesis tool may map the local state to a separate memory segment and allow it to run concurrently. If the transaction remains in the same thread as its parent or peers, then the synthesis tool may remove copying altogether and ensure the same behavior by scheduling transactions in a particular order (essentially sequentializing

them such that the data dependencies preserve the illusion of copying without the unnecessary overhead).

### 3.3.4 Token-based Control

Control flow between transactions is handled through token-passing – when a transaction completes, it creates tokens that determine the next set of transactions to start. Each transaction contains a guard, describing the tokens that must exist before it can begin. Tokens are identified with a unique name. Each transaction has a *guard* expressed as a Boolean expression of token identifiers, enabling complex token control. Once the guard has been satisfied (i.e. the required tokens have been created by other transactions) all of the tokens involved are consumed atomically. Thus, a transaction is *guarded* by tokens. Tokens primarily describe functional dependencies between transactions (independent of timing). Their existence implies a local dependency network similar to traditional control-flow techniques.

Limitations in control expressability ensure that control lifetime is always bounded. The semantic model’s policies disallow transactions from arbitrarily observing tokens. A token’s lifetime begins when its creating transaction commits, and it ends once it has been consumed. This decision enforces a limit on the lifetime of control state. To cover many practical applications, conditional token creation is allowed – that is, tokens can depend on the value of a variable. In general, data-conditional control is difficult to bound both in lifetime & scope – verification requires knowledge of the temporal longevity of any control decision, otherwise it leads to the halting problem.

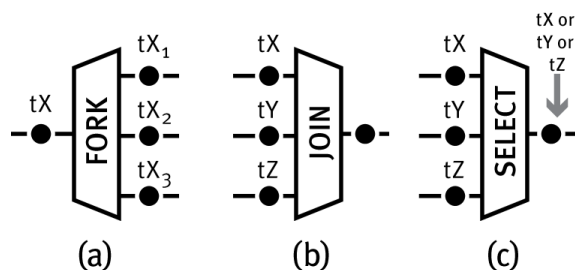

Figure 3.2: (a) FORK nodes replicate tokens when multiple transactions are guarded by the same token. (b) JOIN nodes wait for all input tokens to arrive before generating its output token. (c) SELECT nodes wait for any input token, discarding the remainders.

In this model, however, every operation (including token creation and consumption) falls on a well-defined transaction event. The compiler can always fully analyze control dependencies, conditional or otherwise. Whole-system analysis for well-constructed hierarchies is pseudo-linear, since any high polynomial or exponential behavior for a small number of elements is insignificant. Thus, the compiler leverages abstraction to keep average runtime linear – it can very quickly determine all of the conditions that lead to a given transaction’s creation. The tool always knows the transaction boundary that a variable falls on and can determine whether a token condition is satisfied during its execution.

### 3.3.4.1 Combining and Forking Tokens

Latency tolerant designs require complex control mechanisms to implement real applications[21, 22]. Three control nodes manage merging and bifurcation: FORK, JOIN, and SELECT. If multiple transactions are guarded by a token, the

token gets replicated and each transaction gets its own copy. This induces a FORK node, where the created token forks into multiple transaction guards, as shown in fig. 3.2(a). Abstract synchronization is provided through a JOIN mechanism shown in fig. 3.2(b). A transaction guard of “TOKENA and TOKENB and TOKENC” implies that the transaction will wait for all three to exist before it may fire. Thus a JOIN node is inferred and automatically inserted into the network at the appropriate location. Complex control applications often require an “either-or” selector. A transaction may specify a guard that states this relationship through a guard of e.g. “TOKENA or TOKENB or TOKENC” shown in fig. 3.2(c). A generated SELECT node will wait for any of the tokens to arrive before proceeding. The subsequent tokens are ignored. SELECT nodes proceed regardless of the order in which their input tokens arrive.

### 3.3.5 Latency Tolerance

Latency tolerant design is a natural approach to heterogeneous design, particularly because behavior that is decoupled from timing encourages the design of a *family* of executions, rather than a fixed, implied schedule. Covering an array of valid execution sequences allows tools to evaluate implementations across multiple timescales, supporting true decoupling from application specification and improving design resilience against evolving architectures. The methodology forces designers to reduce their specification to a minimal description of the problem being solved. This frees them from including hard timing details at a large scale, which may not be relevant until design space exploration, when tools have a better sense of costs. Hard timing details generally affect lower-level implementation,

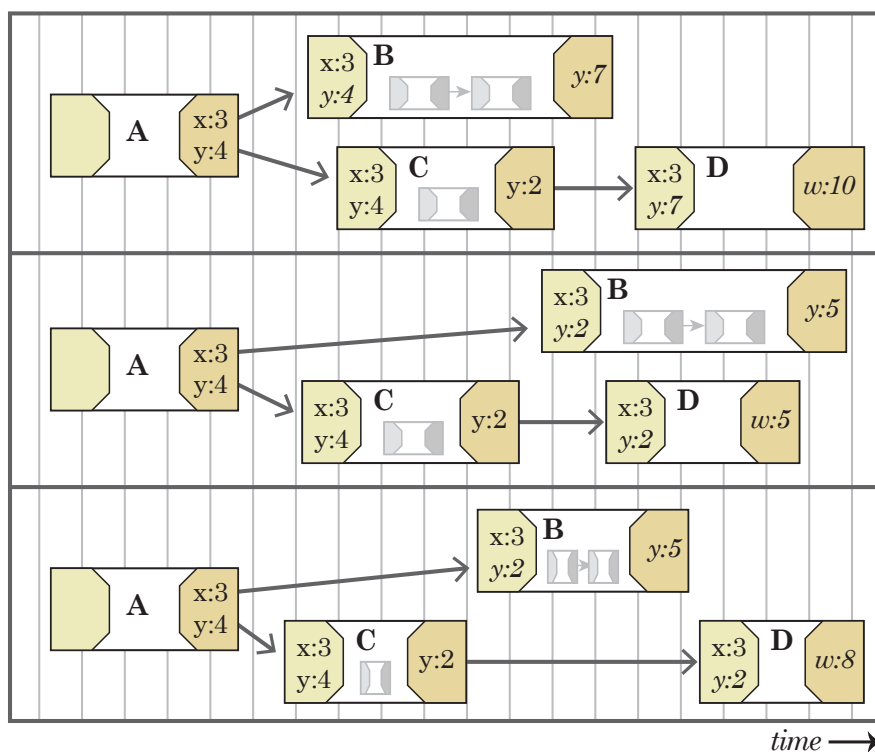

Figure 3.3: The same transactions from fig. 3.1 shown executing in different orders. As is demonstrated, the internal workings of transactions B & C do not need to be included. They are abstracted along the transaction boundaries. This idea is crucial to bounded concurrency analysis.

and these constraints are captured in the resources rather than the application specification.

Work in the area of latency tolerant design typically refers to gate-level isolation of clock domains. This semantic has generalized the approach, but applies similar control semantics through the token-based control network presented above [21, 22].

### 3.3.6 Upholding Abstraction

Hierarchical transactions uphold a combination of functional, temporal, and spatial abstraction:

1. Temporal abstraction is achieved through latency tolerance and by bounding data/control lifetime. Application specifications omit explicit timing information, reducing the problem to fundamental functional dependencies. Transactions tie data/control lifetimes to the length of the transaction.
2. Functional abstraction comes about by wrapping all behavior within finite-length transactions. The internal behavior of a transaction can be abstracted at the transaction's start and end events.
3. Spatial abstraction is enabled through locality of data/control. All design variables and control decisions are local to their transactions. Data containment means operations do not need to go beyond their local transaction scope.

### 3.3.7 Concurrency

To encourage maximal concurrency wherever possible, hierarchical transactions are designed to be concurrent unless otherwise specified. With the added parallelism of concurrency comes a host of difficult-to-find concurrency bugs. Typically, these problems emerge when concurrent tasks share resources, and the arbitration of those resources occurs in an unexpected order. Specifically, they give rise to race conditions (where data is written multiple times by concurrent tasks),



potentially leading to deadlock or starvation. Decades of research have provided designers with tools to debug these notoriously cumbersome bugs.

Concurrent transaction commits to the same variable have a high possibility for race conditions. Figure 3.3 illustrates how transactions may commit different values in different execution orders (using the same design from fig. 3.1). As shown, the values  $y$  and  $w$  are written with different values in each execution. When a designer specifies an application in this form, they are indicating to the tools that *this is correct behavior*. The designer is essentially letting the tool know that functional correctness does not depend on the value being overwritten by multiple transactions. In situations where this may be critical, the compiler quickly identifies race conditions (sec. 6.2.5), reporting them to the designer to resolve.

# Chapter 4

## Hierarchical Guarded Atomic Rule-based Language

### 4.1 Introduction

A fundamental rethinking of cosynthesis specification semantics provides the opportunity to explore a novel domain-specific specification language better suited to the task.

With any new semantic model comes the choice between designing a new specification language or writing a library over an existing language (leveraging existing technology to form the meta-language, i.e. compile-time language). The former requires a significant amount of initial work, especially in testing as language coverage is an often intractable problem. The latter library-based approach is cumbersome, making designs difficult to express while potentially limiting specification strength due to inherent drawbacks from the parent language. This research explores the former path via a language that directly and compactly reflects its underlying transactional semantic model. Despite significant setup effort, the

payoff is in the ability to concisely express complex designs without any potential pitfalls.

### 4.1.1 Existing Languages

There are many programming, hardware design, and abstract model languages in use; most reflect their respective tools' function. Often, however, languages are used simply because of familiarity. C is one such example.

C, however, is ultimately an implementation specification, not an algorithmic one. Real-world high performance C code is optimized for cached CPU architectures, and thus is built on certain assumptions about how information is exchanged in the system. Optimized C is structured around different system metrics, particularly in arithmetic versus data motion costs. For instance, since floating point operations are generally expensive in microprocessors, arithmetic-heavy C implementations will improve performance by introducing conditional cases when the value is zero, avoiding the unnecessary computation. In an ideal specification, however, such an optimization would not appear; it would instead eliminate any implementation-specific details in favor of pure algorithmic descriptions.

Bluespec<sup>1</sup> is a rapid development language that enables very fast design iterations of operation-centric applications. Quick design iterations allow developers to determine the primary costs of the system early in the design process – often, these costs can be counterintuitive or non-obvious. Encouraging a rapid design cycle

---

<sup>1</sup>BlueSpec® is a registered trademark of Bluespec, Inc. SystemVerilog® is a registered trademark of Accellera, Inc.

exposes the costs, and allows designers to manually restructure their architecture accordingly.

Traditional approaches to co-design use SystemC or similar languages. Recent work in Bluespec SystemVerilog<sup>1</sup> [58, 73] applies guarded rule-based reactive techniques to this field, and has demonstrated the trade-offs involved. In this work, we present a custom language aimed at directly capturing hierarchical transactional semantics, enforcing specification limitations as an efficient representation.

### 4.1.2 Aesthetics

Specification aesthetic refers to an application’s ability to clearly and unambiguously express the designer’s intent. In its purest form, a given specification would aim for true implementation independence boiled down to a concise, practical, and understandable description of its core algorithms.

HTL syntax is modeled after Python for its attractive minimalist syntax that is well-suited for algorithm-level specification. Further, whitespace-defined scope provides a clean visualization of hierarchical scoping without the clutter of e.g. semicolons; at the same time, whitespace-tied blocks are difficult to manage for depths greater than 4 or 5, therefore encouraging designers to break up the design into much smaller pieces. This has the added advantage of encouraging more hierarchy than is strictly necessary, a property that grants analysis tools more flexibility. Fine-grained, deep hierarchies come at no additional cost. Unlike Python (or other hierarchically scoped software languages), there isn’t a scope context change or stack overhead.

## 4.2 Core Language Philosophy

### 4.2.1 Concision, Meaning, and Abstraction

Conventionally, an application may be specified with a specific architecture in mind. As the architecture evolves, some of those elements may not be reasonable assumptions. Rather than rely on the the input specification to detail implementations suited for the architecture, it should describe the overarching goal with as little extraneous information as possible. This is one of the core issues plaguing C-to-RTL tools: C specifications for e.g. signal processing applications are not inherently concurrent, nor are they designed around the potential for distributed memories that may not be able to maintain coherency without significant overhead. There are more subtle effects as well – hand-optimized FFT implementations may include zero-checks to avoid expensive floating point computations. When translated to RTL, those checks introduce unnecessary performance-hindering synchronization. More significantly, since the original specification targets a single-access, large memory, it is the compiler’s responsibility to infer local strides of data access which can be mapped into small, distributed memories.

The ideal cosynthesis language decouples algorithm specification from implementation, while still supporting synthesis of high-performance realizations. The language presented below aims to fulfill this goal.

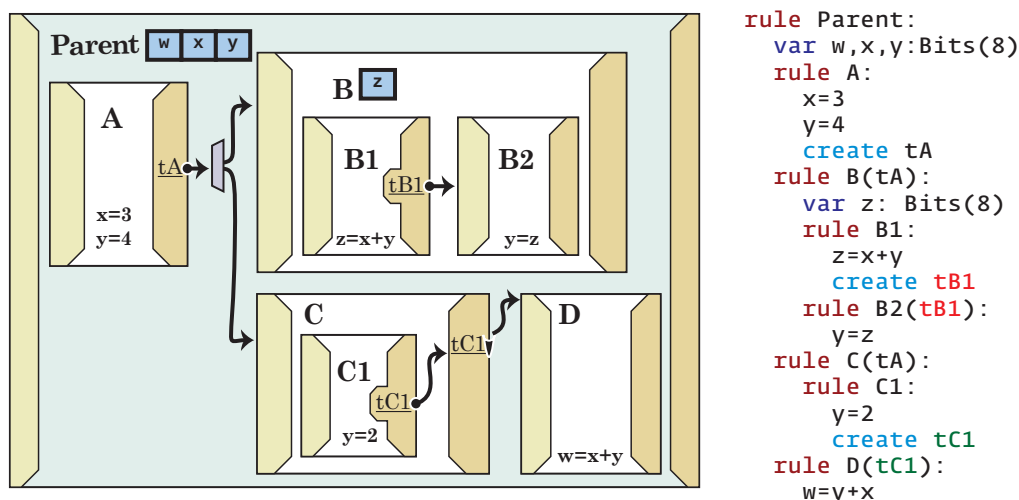

Figure 4.1: Example of token-guarded hierarchical rule language used to specify transactions. This code describes fig. 3.1.

### 4.3 Rule-based Language

The Hierarchical Transaction Language (HTL) allows direct specification of transactional semantics in a clear, concise way. The fundamental task expression is a guarded, hierarchical rule. Guarded rules provide a natural fit for reactive, concurrent systems, efficiently representing latency tolerant, high-level behavior. Every rule describes how a transaction begins along with its child relationships or its internal functionality. Fig. 4.1 outlines the syntax, providing code for the transactions shown in fig. 3.1. Indentation specifies scope, similar to the Python language. The language is statically typed and scoped, thus all variables must be declared and their types must be statically resolvable. Types are expressed using compile-time “duck typing” – as long as an object can implement the specified behavior, it is a valid type relation. The data types are constructed from components

in a library of generic type components commonly needed to express applications. In the example shown, the `Bits` class represents arbitrary finite-length integers supporting standard arithmetic operations, concatenation, and logic-level bitwise operations (shifting, masking, etc.). They translate to e.g. registers in hardware and character arrays in software.

Scope (namespace and variable access) is static, tied to the transaction generated by the rule.

### **4.3.1 Meta-language vs Language**

There are two classes of specification: language features that directly describe the target semantic or execution model, and a meta-language that adds one layer of abstraction through compile-time expression. Put another way, a meta-language allows code that generates code. As a language's design evolves and the demands for concise expression of its behavior increase, a common lesson learned by language designers is that any practical specification language benefits tremendously from a meta-language. Automating and parameterizing repetitive behavior and variable types improves readability, and broadens the usability of a given specification. Without a meta-language, for example, a designer would need to manually specify separate design instantiations for different types or architectural choices, despite using the same fundamental algorithm.

Moving beyond trivially sized problems, it is beneficial to allow expression of meta-behavior; that is, language features that produce language that is then translated to compiler data structures and eventually code. A meta-language, in this context, refers to specification code that is used to describe design parameters,

i.e. behaviors that are indirectly related to the task that needs to be done. In the C++11 specification, for instance, template metaprogramming is a powerful technique that allows parametric classes with rather complex generating behavior. One of the drawbacks, however, is it is syntactically unwieldy and provides a different expression language over an existing one.

An incidental benefit of transactional semantics is rich static analysis. The same guarantees that allow data & control mobility also grant the compiler valuable information about the behavior of variables. If a variable is written once and read the remainder of the design, it will determine its write-once value and propagate it throughout the design. By adding this same functionality to types and functions (through compile-time function evaluation), the same language is used for both the application expression *and* generating parameters. Thus, the Hierarchical Transactional Language (HTL) is both a language and a meta-language using precisely the same semantics and syntax.

## 4.4 Syntax

This section will introduce the HTL syntax, providing small demonstrative examples.

**Typographical Conventions** Typographical formatting uses `sans-serif` to describe variable identifiers, rule identifiers, token identifiers, type names, and keywords. As a matter of convention, tokens are identified with a lowercase “t” followed by a capitalized semantic name. Rule and class identifier are capitalized,



while variables are generally all lowercase (with the exception of large arrays and iterators, which use an uppercase letter convention). The designer is free to use any legal identifier that suits their specification style.

**Whitespace Scope** Whitespace determines scope blocks. A tab character, or a series of spaces coalesced, determine a lexical `INDENT` token in the lexer.

**Scoping Rules** Scope is syntactically defined, and constrained to source files. Each source file is treated as a module containing rules and classes. If a given rule in file `A.hr` instantiates a rule in `B.hr`, they remain separate scopes. This *ruletree/source* scope preserves readability. In any case where scopes need sharing, they are done so explicitly to communicate intended and expected behavior.

**Identifiers** All rules, variables, types, tokens, and classes are represented with unique identifiers. Identifiers must begin with a letter or underscore, followed by zero or more alphanumeric or under characters thereafter.

**Rule Identifiers/Rule Scope** Rule identifiers are scoped to their parent. Identifiers may be duplicated for different trees; however, the compiler maintains a global rule identifier list for a given source file. It issues toggleable warnings in case of a name collision; this enforces unambiguous identifiers.

**Variables** Variable identifiers are scoped to their parents, and every descendant of the parent in the same source file. Variables follow *ruletree/source* scope. Rule instantiation (via a `call` statement) delineates a new scope.

Variables are declared with the `var` statement, followed by a list of variable identifiers, a colon, and a type instantiation. If multiple identifiers are provided, each one receives its own type instantiation – it is equivalent to separate `var` statements for each identifier.

**Types** Type instantiations consist of the type name (i.e. one of the built-in types or a user-defined class), and its specific parameters in order of the declaration. All types must be statically resolved at compile time – parametric designs are realized by allowing variables in the type declaration under the proviso that the variable’s value is constant and determinable by the compiler.

**Tokens** Tokens are declared implicitly by use. A `create` statement declares a token. Any token guards containing a token with the same identifier will have that token in its guard. Note that token scoping is different from variable scoping: they are semi-global to the rule tree in which they’re created (again, limited to the source file).

Tokens can only be passed up the hierarchy. The compiler reports an error when a token is created by a rule and guarded by the child of one of its peers, as that behavior is undefined.

#### 4.4.1 Rules

A rule consists of the `rule` keyword followed by an identifier, and an optional guard. It then contains a statement block with either variable declaration and child rules, or variable declarations and atomic statements. The two cannot

be mixed – rules can either be hierarchical containers or leaf nodes with state-modifying actions.

The simplest rule contains no guard and no statement (the `pass` statement indicates no behavior):

```
1 rule Foo:
2   pass
```

A rule's guard can be a Boolean combination of token identifiers expressing the condition under which it can fire:

```
1 rule Bar(tX and tY):
2   pass
```

In this case, rule `Bar` will wait for *both* tokens `tX` and `tY` before it executes.

If no guard is present, then the rule may begin whenever its parent begins (potentially after some initial latency). In the following example, child rules `B0` and `B1` may run in any arbitrary ordering; since there are no dependencies expressed, any ordering is assumed valid.

```
1 rule B:
2   rule B0:
3     x = 1
4   rule B1:
5     y = 1
```

Tokens can only be passed among parents and ancestors. The following demonstrates a valid hierarchical token transfer:

```
1 rule Top:
2   rule Child1:
3     rule A:
4       create tA
5   rule Child2(tA):
6     create tB
```

In this example, rule `Top` begins, then `Child1` executes. Its child, `A` begins and creates token `tA`. Since none of `Child1`'s children contain `tA` as a guard, and since there are no more outstanding rules to execute, `Child1` terminates – however, it

commits token `tA` to its parent `Top`. The token is then passed to the guard of `Child2` which may now execute.

The following is an example of an *invalid* token transfer:

```
1 rule Top:
2     rule Child1:
3         create tA
4     rule Child2:
5         rule B(tA): # illegal
6             create tB
```

This is undefined behavior and will cause an error. After `Child1` executes, it would need to pass `tA` to `Child2`. However, without a dependency between the two, `Child2` may execute *before* `Child1`. Further, even if `Child2` executes after `Child1`, the implicit dependency makes the code unintuitive and difficult to follow.

## 4.4.2 Atomicity

Rule bodies are atomic. They only need to be ordered due to naming declarations – e.g. create statements must come before the token’s use in a guard, encouraging human-readable code.

Any conflicting writes follow the same rules as Verilog. The last (in source code order) of the valid assignments are accepted. Consider the following rule:

```
1 rule T:
2     x = 1
3     x = 2
4     x = 3
```

Only the last of the three assignments (“`x = 3`”) is synthesized. The other two assignments are removed.

It is important to bear in mind that atomic statements mean that ordering is important only for resolving ambiguous concurrent assigns.

```
1 rule T:
2     if x > 1:
3         y = 1
4         y = y + 1
```

All of the references to `y` on the right side of assignments are the *same value* – they are the value that was atomically read in at the beginning of rule T. The values on the left sides refer to the value being written. The above example is equivalent to:

```
1 rule T:
2     if x > 1:
3         y_out = 1
4         y_out = y_in + 1
```

Thus, the way to interpret this is that the conditional block is obviated, as it will always be overridden by the second assignment.

### 4.4.3 Conditional Statements

Conditional statements are very similar to Python: an `if` keyword is followed by a condition, a colon, and a block statement. It may be followed by `elif` statements and a final optional `else` statement.

Internally, the compiler rewrites statements into a declarative form, coalescing conditions into independent atomic statements.

For example:

```
1 if x:
2     if y and z:
3         create tA
4     elif w == 1:
5         create tB
6     else v == 2:
7         create tC
8     create tD
9 else:
10    create tE
```

internally translated into the following independent atomic statements:

```
1 x and (y and z) -> create tA
2 x and not(y and z) and (w == 1) -> create tB
3 x and not(y and z) and not(w == 1) and (v==2) -> create tC
4 x -> create tD
5 not x -> create tE
```

The latter format is ideal as an intermediate, compiler-interpreted language as it simplifies and decouples `create` statements. For many designers, however, it is unintuitive and difficult to extract its high-level meaning, hence a natural and familiar `if/else if/else` syntax.

#### 4.4.4 Rule Instances

Design reuse is pivotal to ensuring ease of IP integration, specification longevity, and amortizing testing effort over multiple applications. Functions in sequential software and modules in HDLs serve the same fundamental role: they allow behavior to be self-contained (thus making the specification manageable), and allow reusability. Further, they provide designers a way to intuitively break down an application into its subparts, making the code easier to read, maintain, and isolate problems in. While the transaction hierarchy provides this functionality, it would be cumbersome and unreadable to specify full designs within a single, deep hierarchy. Rule instances allow easy code management and organization, parameterized rules, and provide an easy-to-understand reusability mechanism.

##### 4.4.4.1 Rule Instance Syntax

Rule instances use the `call` statement followed by the name of the rule and input arguments. Since the token naming scope is semi-global, token namespaces between caller and callee are kept separate. Otherwise, the token namespace

would become polluted causing token identifiers to collide. For example, if the rule `process_data` is called and it creates a token internally named `tDone`, and the caller also contains a token with the same name, it would likely raise compiler errors due to poor token scoping.

For example, consider the following:

```
1 rule Top:
2     rule setup:
3         create tDone
4     rule caller(tDone):
5         call Foo
6
7 rule Callee:
8     rule do_some_work:
9         create tDone
```

To resolve this, all calls are optionally block statements containing a token identifier map via the `creates` keyword (explained further below). Control tokens can now pass from callee to caller, but only through explicitly defined means.

**Arguments** Input arguments are passed either positionally or by name, following Python's syntax rules. While optional arguments are not yet allowed, named arguments provide the benefit of clear code documentation

```
1 call Callee(arg1, arg2, named_arg=arg3)
```

**Return Values** Callable rules may return a value via a `return` statement followed by the expression being returned. Type is inferred, and all callable rules are untyped by default. In the following example, rule `add` is called with arguments `a` and `b`. The return value is the summation of the two input arguments.

```
1 rule add<-(x, y):
2     return x + y
3 call sum = add(a, b)
```

Note that callable rules are full-featured and follow precisely the same semantics as non-callable rules. In reality, the compiler makes no internal distinction – it simply tags certain rules with argument requirements. To facilitate flexible and parametric design, arguments may be variables, expressions, or type templates. In the following, rule `foo` receives a type template for a `Bits` type (with bitwidth of 32). Within `foo`, variable `intermediate` instantiates its type based on the provided template. The compiler will infer types based on use, and thus there is no need to provide any extra information about the argument.

```
1 rule foo<-(type, x, y):
2   var intermediate: type
3   rule setup:
4     intermediate = x + y
5     create tNext
6   rule next(tNext):
7     intermediate += 1
8     return intermediate
9
10 call v = foo(Bits(32), a, b)
```

**Token Maps** Token maps are optional statements contained within call blocks that specify the tokens to export from the callee. Additionally, the designer may rename tokens to prevent namespace pollution.

```
1 call Callee(...):
2   creates tDone->tCalleeDone, tError
```

### 4.4.5 Functional Rule Instances

A functional rule instance returns a value, and can be treated as a preamble. If rule `A` calls functional rule `foo`, then `foo` is an instanced rule that executes before rule `A`'s body. Thus, it reads the same data that `A` reads. The return value of the



functional rule is made available to A. Note that all of this behavior is implicit – the compiler manages ordering and correct rule execution.

Consider the following code:

```
1 rule Top:
2   if add(1, 2) > 1:
3     create tCorrect
4
5 rule add<-(x, y):
6   return x + y
```

Internally, the rule executes identically to the following code:

```
1 rule Top:
2   var r: Bits(2)
3   rule do_add:
4     r = x + y
5     create t_do_body
6   rule do_body(t_do_body):
7     if r > 1:
8       create tCorrect
```

#### 4.4.6 Classes

Managing design complexity is eased through abstraction models. Arguably the most common such model is the class object – it packages state and behavior such that internal intermediate actions do not need to be exposed to other components in the design. Classes in HTL specify a user-defined type and may contain internal parameterizable data along with rules to modify that state. They encourage object-oriented and help organize large applications into logical sub-components.

Compared to other languages, HTL classes must follow certain rules in order to remain compatible with transaction semantics. When a class object is read by a rule, it is read-in as a whole. Likewise, when it is committed, it is committed as a whole.

Classes may contain parameters that conform to “duck typing.” As long as the compiler is able to determine a parameter’s type statically, the code is valid. There are no private variables – all variables in a class are public. It is up to the developer to enforce reasonable access rules, following Python’s access semantics.

#### 4.4.6.1 Instantiation

A class is instantiated by declaring a variable with its type. Consider the following code:

```
1 class Foo:
2     var x, y: Bits(16)
```

Class Foo is instantiated through a declaration, such as:

```
1 rule Top:
2     var f0: Foo()
```

#### 4.4.6.2 Parameters

Parameters are passed to the class at type instantiation. Below, Foo is extended to include a `bitwidth` parameter:

```
1 class Bar<-(bitwidth):
2     var x, y: Bits(bitwidth)
```

And instantiated using:

```
1 rule Top:
2     var b0: Bar(32)
```

Note that the parameters are untyped – instead, their type is determined valid if they are used correctly. In the example, an integer is a valid type for this specific instance of the class, since it is a valid type for the `Bits` class.

Not only can type parameters be arbitrary types, they may also be used as type *templates*. A type template simply passes an uninstantiated type along with

its parameters. Below, the same class is now made generic to accept any type template:

```
1 class Baz<-(T):  
2   var x, y: T
```

A valid instantiation must provide a full type instance.

```
1 rule Top:  
2   var bz: Baz(Bits(24))
```

When the compiler encounters a type declaration, it creates an internal type template. This may be passed as a parameter, or it may be turned into an instantiation if it appears in a variable declaration statement. Clearly, an integer type parameter (`var bz: Bar(16)`) would cause an error: 16 is not a valid type template.

Type parameters must be statically resolvable when the compiler reaches the variable declaration. Consider the four declarations below:

```
1 var x: Bits(16)  
2 var y: Int(20)  
3 var z: Bits(y) # Ok: compiler knows y is a constant value  
4 var v: Bits(x) # Not statically resolved
```

An Int object is immediately tagged as static (they are read-only), and thus the declaration for `z` is valid. The declaration of `v`, on the other hand, is illegal: its bitwidth cannot be determined at compile time.

### 4.4.7 Parametric Class Examples

Constant analysis enables parametric types – the following examples demonstrate a container class for complex numbers and a simple matrix class containing a scalar rule.

#### 4.4.7.1 Complex Class

```
1 class Complex<-(type):  
2   var real, imag: type  
3   var C: Complex(Bits(16))
```

During object instantiation of `Complex`, the type instance `Bits(16)` is passed as a parameter with the identifier `type`. In the body of the `Complex` class, two variable declarations `real` and `imag` are issued the `Bits(16)` type. In this particular case, the type parameter can be any available type. If, however, the owner of the `Complex` instance attempts to perform addition and multiplication on the class's members, and they do not support the operation, the type checker will raise a compiler error.

#### 4.4.7.2 Matrix Class

```
1 class Matrix<-(type, N, M):  
2   var mem: Array(type, N*M)  
3   rule scale<-(self, scalar):  
4     for x in IRange(mem):  
5       x *= scalar  
6   # ...  
7   var M: Matrix(Bits(32), 16, 16)  
8   # ... operations to load the matrix ...  
9   call M.scale(1.0)
```

Similarly to the `Complex` class, the `Matrix` object creates an member of type `Array` whose elements are typed `Bits(32)`. The size of the array is computed statically and a call to `scale` executes a simple iteration where each element is multiplied by the scalar.

Clearly, the code is concise and legible at first glance without sacrificing performance simply by restricting specification expression power.

### 4.4.8 Modifiers

Pragmatic statements communicate certain semantic information to the compiler. Modifiers use the following syntax:

```
1 @modifier_name(arg0, arg1, ...)
2 rule foo:
3     pass
```

They are particularly useful for iterators, discussed in the next section. Often, in order to preserve static data types, it is important to force an iterator to unroll and resolve its data type. Modifiers used in the Fast Fourier Transform example (Appendix B.1) to specify how information passes between stages and to ensure that the types are statically and correctly resolved.

## 4.5 Compiler

The Hierarchical Transaction Scheduler and Synthesizer (HTSS) compiles and simulates HTL. It includes a rich type and iterator library, race condition detection mechanism, a static analysis engine to allow design parameterization via inferred constant variables, scaffolding synthesis (internal bookkeeping such as token dependencies and variable read/write cataloging), a high-level transaction-level behavioral simulator, and a synthesis back-end.

Integration of all of these components, as well as associated compiler-specific options (e.g. whether to unroll certain iterators) is aided through a built-in TCL parser. Design scripts can be written to simplify and automate the overall design flow. While the initial implementation is simple, a built-in scripting engine has the

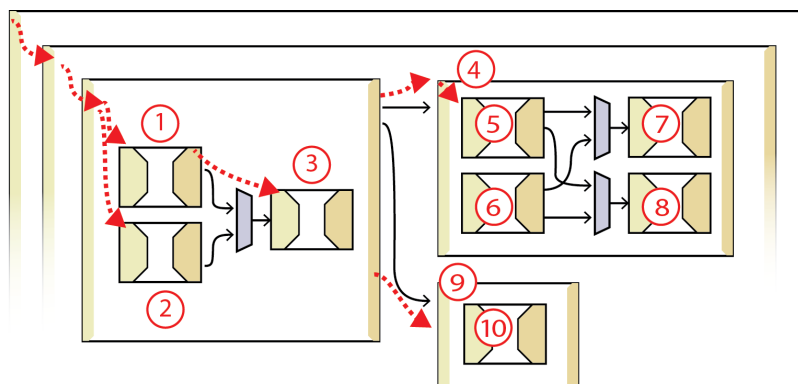

Figure 4.2: Rule tree traversal order – it dives into the child rules first, visiting them in topological order based on their dependency. This guarantees that by the time a rule is visited, all of its predecessors have already been visited.

capability of passing constant values as inputs to top-level rules, thereby allowing parametric sweeps and automatic architectural discovery.

### 4.5.1 Parsing

The compiler uses an ANTLR-based parser generator to generate abstract syntax trees (ASTs). Next, it constructs transaction-scale hierarchies, each containing a local AST. It further catalogs all variable declarations and their types (although it does not do type instantiation at this phase).

Once the foundations are set up, the compiler traverses the tree, and from the bottom-up topologically visits each rule. That is, a rule-tree traversal climbs down the hierarchy. At the leaf rules, local AST walkers analyze variable declarations (for type instantiation), conditions, assigns, “create” statements, and call statements.

Next, a local dependency walker iterates through the following visitors:

- **Variable Elaborator:** Catalogs all reads and writes for the rules (including all descendents)
- **Token Analyzer:** Constructs dependencies, appropriately tagging conditional tokens (for later use in closure analysis).
- **Type Analyzer:** Instantiates types for all of variables for this rule. Note that it can leverage any incoming static reads/writes, since it assumes full analysis has already completed for its predecessor rules.
- **Constant Analysis:** Finally, catalog all write statements to determine which, if any, variables are written with constant values.

**Variable Read/Write Elaboration** The simplest, first-cut optimization involves trimming read and write copying where they are not used. If transaction *Parent* contains variables *x*, *y*, *z*, and a child transaction *A* only reads *y*, then there is no reason to copy *x* or *z*.

**Token Analyzer** Token scoping and guard enforcement ensure valid, constructable guards for simulation and synthesis.

**Type Analyzer** The heart of the inferred type engine collects all known constant variable information and creates type instances for each variable, summarizing their specific, resolved type parameters.

**Constant Analysis** Once all of the writes have completed, this module forward propagates constant-value information.

## 4.6 Static Analysis

Unlike traditional sequential software, self-contained data/control scope guarantees behavior that allows straightforward static analysis. Access to state is always controlled and well-defined. The compiler can quickly determine if a variable remains constant throughout its data path. If that variable is later used to conditionally generate a control token, unreachable token paths (and their rules) are eliminated. Since there is no difference between a dynamic variable and one that is detected to be constant, designers can leverage this language feature to yield powerful design parameters, much in the same way they do with HDLs.

In the following example, rules A and B are effectively meta-rules that produce a type parameter for rule C, via the `w` variable.

```
1 rule T:
2   var x, y: Bits(32)
3   rule A:
4     x = 1
5     create tA
6   rule B(tA):
7     y = x
8     create tB
9   rule C(tB):
10    var w: Bits(y)
```

### 4.6.1 Static Analysis for Constant Inference

At compile time, variable access is analyzed to determine if the value remains locally constant. That is, for a given rule, the compiler tracks inherited and



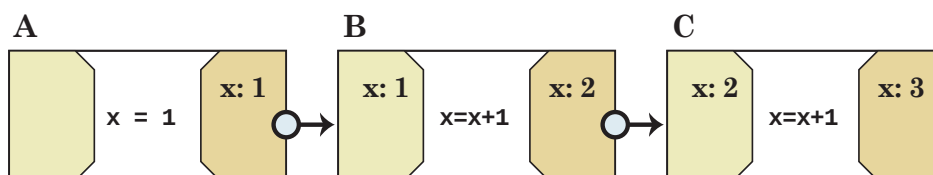

Figure 4.3: Serial rules with local constant values

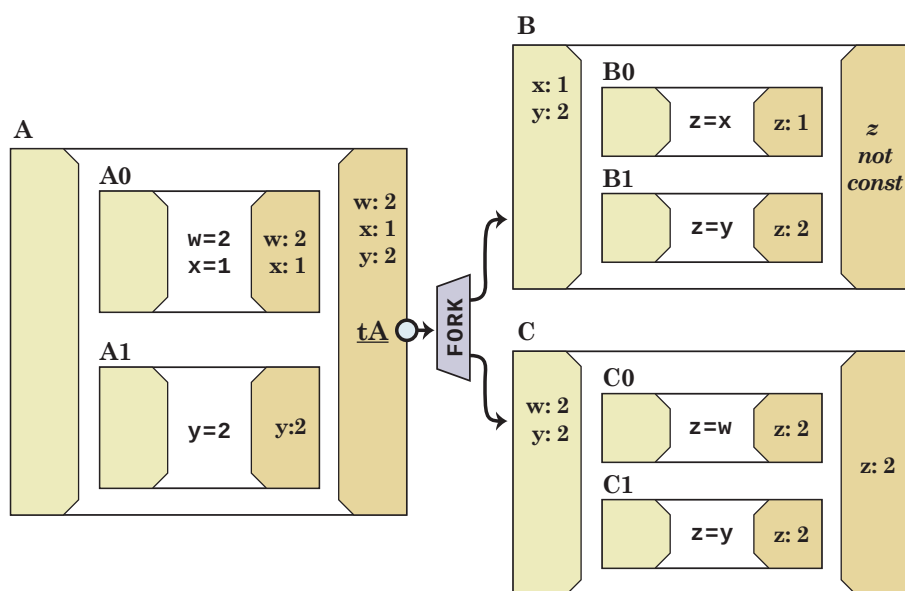

Figure 4.4: Constant inference demonstrating rule-level parallel writes.

owned variables to determine if they hold a constant value for the local rule's scope (independent of any inputs to the system).

Figure 4.3 illustrates local constant values. Consider three serial rules – the static analyzer is able to determine local constant values for  $x$  on a per-rule basis. This is particularly useful if, for instance, a forward rule dependent on B uses  $x$  as a type parameter.

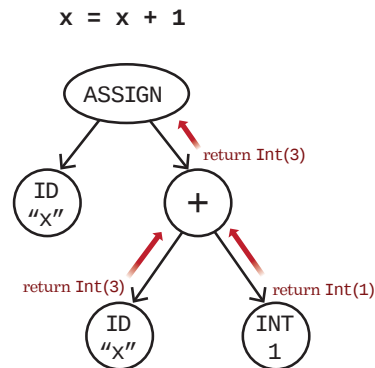

Figure 4.5: AST-level constant value inference – assume that the rule is provided  $x$  with a constant value of `Int(3)`. The AST walker visits each node hierarchically and returns an evaluated result for the sub-tree. If the subtree is not constant (dynamic), then it returns a `NULL` value.

Recall that the static analyzer traverses in topological order. There are two parts to constant inference. The first happens at the AST level. The algorithm visits assignment statements and conditionals.

#### 4.6.1.1 Local vs. Global

Local constancy simply means a variable holds a constant value for its rule and its child rules only. Global constancy applies to every use of that variable.

#### 4.6.1.2 AST-level Constant Inference

**Assignments** An AST walker traverses a rule’s body and attempts to determine the dynamic or constant nature on a per-node basis. Fig. 4.5 illustrates a simple addition statement. In this case, the statement will take the value of  $x$  read in from its parent, increment it, and commit the incremented value. At the top-

level, the walker visits the ASSIGN node. It recursively dives into the right value (RVALUE) node to visit the addition node. This recursively calls its children, starting first with the IDENTIFIER node for  $x$ . Assume that the parent tells this child that  $x$  holds a constant value of 3. The walker will instantiate an `Int` object with the value 3 and return that. Next, the constant literal value of 1 is visited – again, it will instantiate an `Int` with value 1. Back at the addition node, the walker assumes that the typechecker has already ensured that this is a type-valid operation. It takes the `Int(3)` object and executes an addition with the `Int(1)` object to yield a new `Int(4)` object. Back at the ASSIGN node, the walker now sees that the RVALUE has returned a constant value and stores this value into the rule’s write table.

**Conflicts** If there are multiple assigns to the same value, then only the last write is considered valid. The following will still treat  $x$  as a constant value of 2. The first assignment statement is obviated since these are deemed to execute atomically. The simulator issues a warning to notify the developer when this occurs.

```

1  x = 1
2  x = 2

```

Code Fragment:	If $w$ is <b>not</b> constant:	If $w$ is constant:
<pre> if w &gt; 1:   a = x else:   a = y </pre>	<pre> a is constant only if:   If x and y are both constant,   and have the same value. </pre>	<pre> If w's static value &gt; 1:   a is constant only if x is constant If w's static value ≤ 1:   a is constant only if y is constant </pre>

Figure 4.6: Constant inference for “if” statement example

**Conditionals** At every “if” statement, the condition expression is evaluated to determine if it has a constant value. If it does, then the appropriate branch is isolated and visited, and the AST subtree associated with the branch is tagged accordingly (that is, if the expression evaluates to True, then the False branch is marked as “compile-time obviated”). If the condition cannot be evaluated, then it visits all branches (including “else if” and “else” branches). Each recursive call into the respective branches returns a mapping from variable to constant value. The compiler cross-correlates all of the maps and if for every map, a given variable holds a constant value, then that variable is determined to hold a constant value for the entire rule.

Consider fig. 4.6. If  $w$  is not constant, then both branches must be analyzed. The only situation in which  $a$  is constant is if both  $x$  and  $y$  are constant and have the same value. If any of those conditions are violated, then  $a$ 's value cannot be inferred and it will remain a dynamic variable. In the second scenario, if  $w$  is constant, then the branch value can be determined at compile time. If  $w > 1$ , then  $a$  will hold constant only if  $x$  does. Likewise if  $w \leq 1$ ,  $a$  will hold constant only if  $y$  does.

#### 4.6.1.3 Rule-level Constant Inference

Once the leaf rules' internal AST nodes have been analyzed to collect the rule's constant value writes, a rule-tree traversal (again, in topological “forward” order) combines the constant values for multiple rules.

## 4.7 Simulator

The compiler includes a fast simulator amenable to print-based debugging, along with explicitly verbose execution. It maintains a queue of transactions, and dynamically allocates both the space and execution interpreter for each transaction. Tokens are stored within their parent transactions and committed using an event-driven dynamic scheduler.

**Induced Delays** Since the simulator essentially selects a single path of execution through all possible executions, timing variation coverage is addressed through manual injection of specific timing delays. Monte Carlo simulation through random latency injection provides a method of stochastically exploring latency variations. Paired with the conservative exact race condition detection in sec. 6.2.5, the two tools form a powerful method of extracting concurrency bugs.

# Chapter 5

## Iterators

The philosophy behind HTL is to constrain input specification rather than limit the synthesis tool. An egregious source of synthesis constraints in high-level synthesis tools stems from arbitrary access to large, indexed state (i.e. memory). Compared to traditional specification formats, HTL guarantees high performance array access only if designers describe indexed behavior through built-in iterators (see Chapter 8). This puts the burden on the designer to clearly define their intent, while opening opportunities for automatic realizations of dynamic hardware or software to manage otherwise complex indexing. To demonstrate that such a model is practicable, a Fast Fourier Transform (FFT) is implemented through composition of built-in iterators.

### 5.1 Motivation

Practical, real-world applications require a method for representing large collections of related information, e.g. an image, a matrix, etc. Vectored data and matrices form the core of practically all signal processing applications, and provide

a familiar mechanism for representing common algorithms. The copying semantic, however, complicates how large state overhead is mitigated during synthesis. If the indexes accessed are known, then only those values are copied. If they are not known, however, the compiler would have little choice but to institute copying (or equivalent synchronization/caching architectures) for the entire array. For any medium to large array, this is impractical.

In general, arbitrary array access hinders synthesis optimization opportunities. It forces conservative worst-case behavior to ensure correct execution, since the synthesis tool does not have enough information to ascertain which portions of the array may be needed. This leads to unnecessary state copying and transfer.

## 5.2 The Array Primitive

HTL takes a unique approach: it provides an `Array` library primitive with the proviso that arbitrary indexing is explicitly disallowed on this object. Instead, elements of an array are selected by composing built-in, well-defined finite-state iterators. Besides solving the copying problem, iterators alleviate data access uncertainty, avoiding potentially cumbersome and difficult verification. They guarantee lifetime bounds on state, allow easy partitioning of array access, and avoid common pitfalls in verification.

Iterators translate well to other approaches to cosynthesis when converted into data-flow graphs. They guarantee well-formed graphs, allowing designers to leverage any of the existing mature high level synthesis packages. The tools do

not need to apply loop unrolling or analysis heuristics, as the graphs are directed and acyclic. They can thus be directly scheduled.

When indexing is absolutely necessary (and the designer is willing to sacrifice potentially significant performance), indexing is allowed via an `Addressable` library primitive. This object is provided under the assumption that the designer use it responsibly and with knowledge of the resultant performance consequences.

### 5.3 Communicating Designer Intent

In addition to their incompatibility with the copying behavior, variable array indexes are antithetical to the philosophy of clear expression of designer intent. Arbitrary arithmetic index expressions requires symbolic analysis that is very difficult and scales poorly.

For instance, the question of selecting subsets of the array is nontrivial. If access to the array occurs in spans, then the compiler must analyze how data is accessed and attempt to partition or replicate subsets of the array accordingly. Through an iterator, however, this information is directly conveyed to the tool – there is no need for arithmetic or symbolic analysis of index variables.

### 5.4 Execution Semantics

In software contexts, an iteration implies a specific ordering on a data set. In HTL, the definition is split into two parts. Iterators specify complete or partial orders on the *dependencies* between array elements (either within a single array



or, more commonly, across two different arrays). The *execution*, however, is not necessarily beholden to the order in which the iterator generated its dependencies; it simply respects the dependencies induced. Sec. 5.5.4 clarifies this difference with an example.

## 5.5 Syntax & Semantics

Syntactically, an iterator uses a `for` statement providing an iterating variable identifier along with the iterator object. Semantically, these still define transactional behavior. Each iteration is a new transaction; it contains copies of its parent's state, with the exception that it does not copy the source array. It only receives its iteration value(s).

### 5.5.1 Token Scoping

Tokens may pass between rules within an iterator. However, every iterator is treated as an independent token scope. External tokens are created in the `finally` block.

```
1 for x in Y:
2     # ...
3 finally:
4     create tDone
```

Semantically, the `finally` block is a rule that executes after all of the iterations have completed – it is the closure of the full iteration.

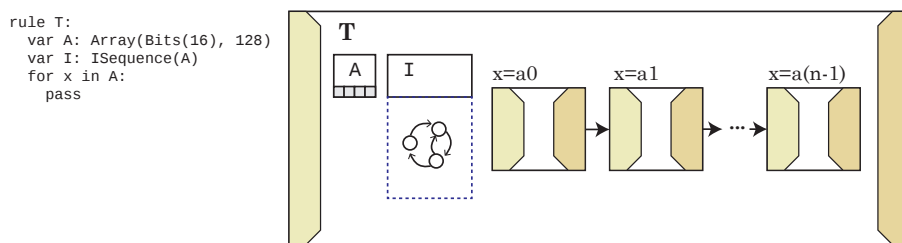

(a) Sequential iterator execution.

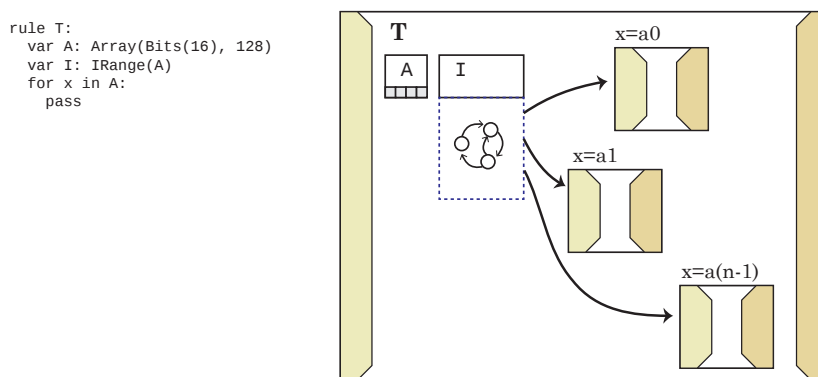

(b) Concurrent iterator execution.

Figure 5.1: Illustration of execution semantics between sequential and concurrent iterators.

## 5.5.2 Sequential vs. Concurrent Iterators

Iterator execution is either sequential (ordered) or concurrent (unordered). If it is ordered, tokens are generated between iteration stages (which, again, are simply transactions). Otherwise, the iteration bodies themselves may execute in any order. Fig. 5.1a illustrates a sequential iterator – all but the first iteration bodies are dependent on the previous iteration. Contrariwise, fig. 5.1b illustrates concurrent iterators – there are no direct dependencies between iteration bodies.

### 5.5.3 Multiple Iterators through Co-iteration

Consider an application which needs to iterate an input array and generate an output in a different sequence. HTL allows co-iteration of multiple iterations via a special double pipe (`||`) composition operator. At every iteration, each of the iterators will provide their iterating value. These values are collected and passed onto the child transaction (the iterator body).

### 5.5.4 Ordering of Iterator versus Iterator Execution

Consider the following example.

```
1 var X: Array(4, Bits(8))
2 for x in IAlternate(X, 0) || y in IAlternate(X, 1):
3   x = y
```

Assume an iterator `IAlternate` selects every alternative element in the array, offset by the second argument provided (0 for the iterator associated with `x` and 1 for the iterator associated with `y`). If the array `X` contained `[0, 1, 2, 3]`, then the above code would be equivalent to the following rules:

```
1 rule FirstIteration:
2   X[0] = X[1]
3 rule SecondIteration:
4   X[2] = X[3]
```

Assume that `IAlternate` executes unordered – that is, it does not induce control dependencies between iteration body transactions. The first iteration may execute after the second. In its *execution*, the iterator is partially ordered. However, the actual index *dependencies* generated by the iterators are completely ordered. It is not the case that, for instance, `X[2]` will get assigned to `X[1]`.

Another way to interpret this distinction is between compile-time iteration and run-time iteration. This view is useful for understanding the concept, but is

problematic insofar as it assumes that iterators are fully unrolled at compile-time. This is not the case – iterators communicate state machines that can dynamically produce indexes and thus can be synthesized accordingly.

## 5.6 Built-in Iterators

Fig. 5.2 illustrates three iterators used for the FFT example below. They are concurrent (unordered) iterators. This does not mean the array is unordered; in fact, these iterators yield each iteration value based on the original order of the array itself. However, there are no control dependencies between iterations, and thus they execute concurrently.

## 5.7 FFT through Iterators

The Fast Fourier Transform (FFT) is a widely used algorithm that exhibits complex indexing and is a prime example of the power of iterators. This is demonstrated through a decimation-in-frequency FFT implementation composed of iterators, illustrating the robustness of the language’s iterator semantics. Recall that each `for` statement follows transactional, hierarchical semantics. Every iteration is a new transaction following the copying mechanism, but rather than copying the entire array (in this case, of inputs and coefficients), the iterators isolate specific elements.

Figure 5.3 lists the heart of the FFT application. Input parameters `size` and `type` are provided. The preamble sets up initial stage count calculations, and

**IRoundRobin(array, length, limit)**

*Skip every 'length' element, until 'limit' cycles have been iterated.*

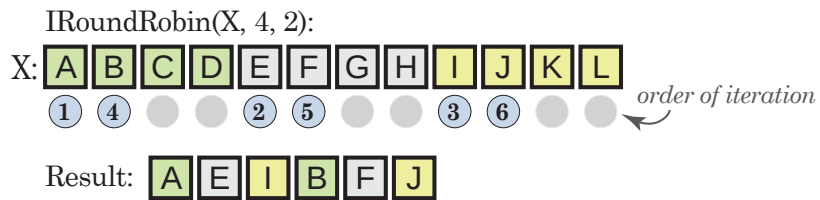

**IClustered(array, cluster\_length)**

*Provide 'cluster\_length' elements in groups each iteration*



**IGroupedRoundRobin(array, rr\_length, rr\_limit)**

*Like IRoundRobin, but provides elements from each group at the same time.*

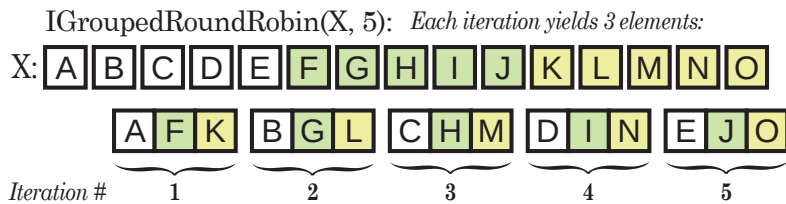

Figure 5.2: Built-in iterators provided to allow FFT indexing

```

1 var stages: Int(math.log2(size))
2 var i_stages: ISequence(stages)
3 var intermediates: Array(size, type) # intermediate results
4 @pipeline(X, intermediates)
5 for stage in i_stages:
6   # Calculate the skip size for this stage
7   var cluster_size: Int(math.pow(2, stages-stage))
8   var rr_size: Int(math.pow(2, stage))
9   # Instantiate iterators
10  var in_clustered: IClustered(X, cluster_size)
11  var coef_clustered: IClustered(Coefficients, cluster_size)
12  var out_clustered: IClustered(intermediates, cluster_size)
13  # Iterate over the sub cluster
14  for in_cluster in in_clustered ||
15    c_cluster in coef_clustered ||
16    out_cluster in out_clustered:
17    # Now iterate within the group
18    var i_in: IGroupedRoundRobin(in_cluster, rr_size, rr_stride=2)
19    var i_coef: IGroupedRoundRobin(c_cluster, rr_size, rr_stride=1)
20    var i_out: IGroupedRoundRobin(out_cluster, rr_size, rr_stride=2)
21    for out0, out1 in i_out || x, y in i_in || coef in i_coef:
22      out0 = x + coef*y
23      out1 = x - coef*y

```

Figure 5.3: Code listing of FFT with Iterators. Each iteration is a new transaction. The double-pipe operator composes parallel iterations – elements are selected from the iterators specified and passed to the iteration transaction at the same time.

defines the outermost stage iterator. Note the “@pipeline” modifier causes the static elaborator to unroll the iterator and compile time, copying information from one stage of iteration to the next. This iterator requires unrolling since intermediate data (`in_clustered`, `coef_clustered`, and `out_clustered`) is dependent on the current iteration value (i.e. the cluster size).

Fig. 5.4 illustrates an 8-point decimation-in-frequency FFT, labeled with the source indices for each stage. The iterators from lines 11-13 grab a sub-array of elements via the `IClustered` iterators. The iterator values yielded (which are themselves `Array` objects) are then iterated upon via round robin iterators (lines 14-16).

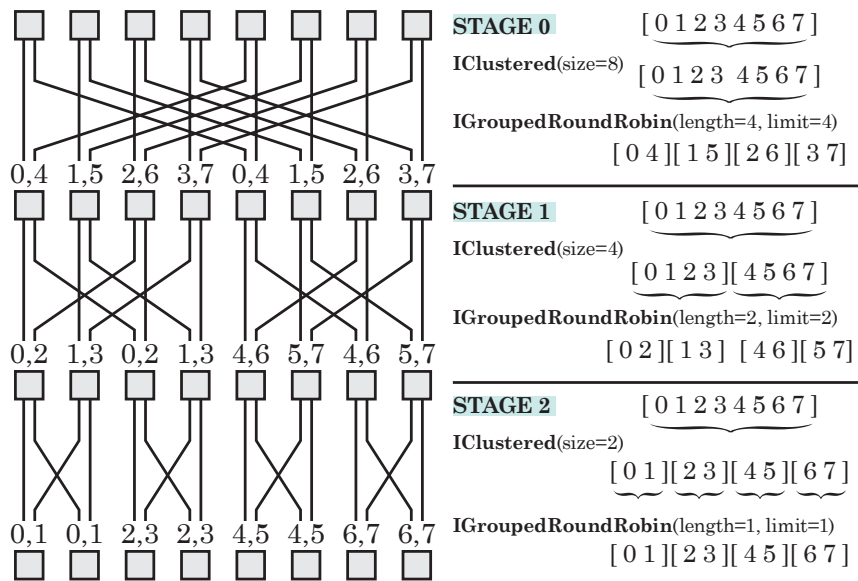

Figure 5.4: FFT indexing achieved through iterators

## Chapter 6

# Practical Analysis and Model Translation

This chapter details practical design analysis of hierarchical transactions. The first concern is a closure mechanism. In the semantic model, a transaction completes once all of its children that can run have completed (i.e. any child that has had its guard satisfied). An open-ended implicit condition allows domain-appropriate implementations. Realizing closure in software versus hardware lead to rather different solutions.

The second concern is race condition detection. The combination of latency tolerance and concurrency leads to potential operational ordering sensitivity which can lead to deadlock. A scalable, conservative method for identifying possible race conditions is presented and discussed.

Finally, in order to demonstrate that hierarchical transactions are in fact capable of efficiently translating to existing models, this chapter outlines methods of translation to pure functions and control/data-flow graphs that can leverage existing high-level synthesis solutions.



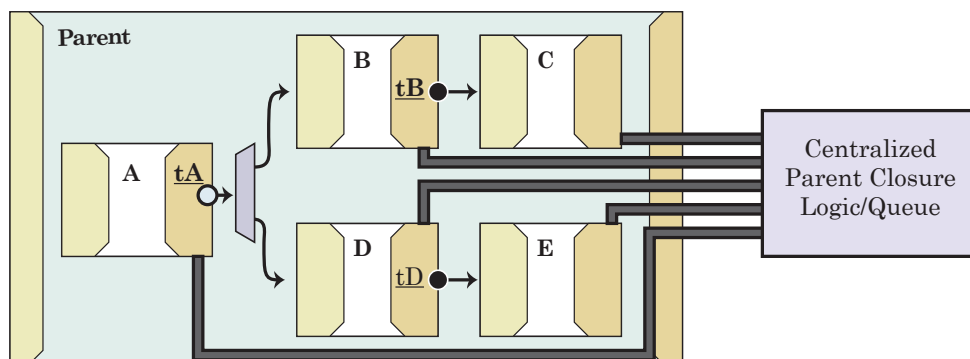

Figure 6.1: Centralized control to determine parent transaction termination

## 6.1 Closure & Distributed Transaction Control

Transactions can be directly executed for simulation, verification, and (when managed correctly) implementation. Improving performance of all three enables rapid development – faster simulation translates to shorter development time.

During direct execution, the issue of when to terminate a parent transaction needs to be addressed, referred to as its *closure condition*. The simplest approach uses a central controller with full knowledge of every child transactions state, along with a queue of outstanding transactions. Fig. 6.1 illustrates the inserted logic required to determine when transaction PARENT completes – namely, it must observe the state of all transactions. If all transactions have completed, and there are no outstanding transactions in the queue, then the parent transaction may terminate.

While this approach is correct, it may not be suitable when executing transactions in e.g. hardware where a queue is not feasible due to resource constraints. Instead, a more efficient approach determines all possible conditional execution

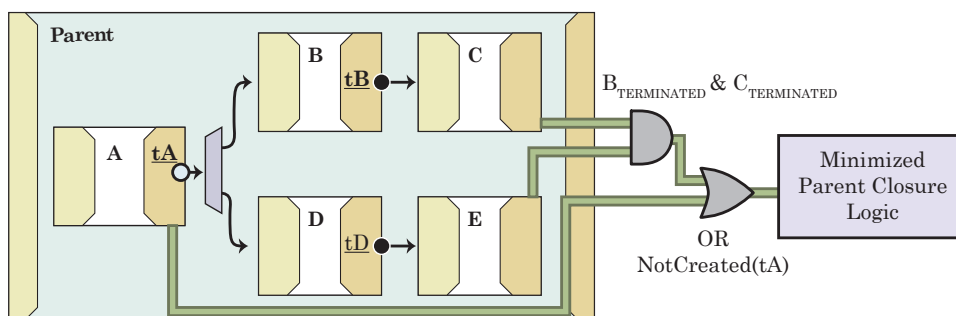

Figure 6.2: Centralized control with synthesized logic to determine parent closure.

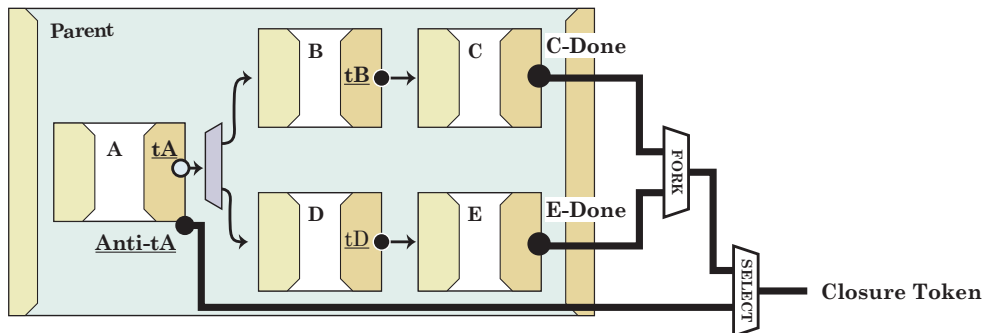
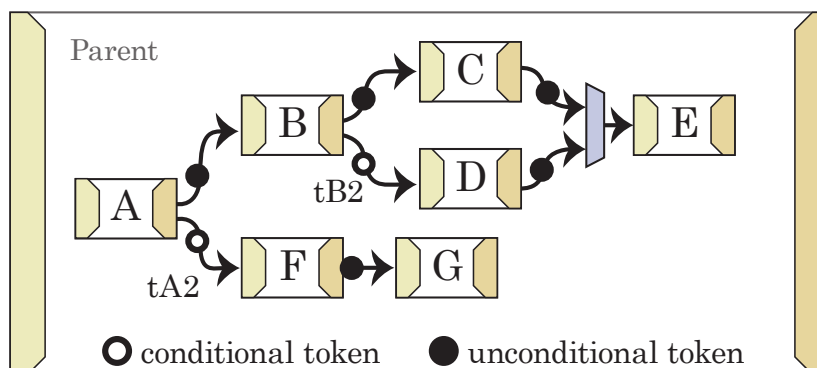

Figure 6.3: Distributed control using counter tokens to implement synthesized closure logic.

paths and synthesizes logic accordingly. In the example, transaction A creates a conditional token  $tA$ . Synthesized logic would check for one of the following conditions: either token  $tA$  was never created, or token  $tA$  was created and both transactions C and E have terminated. Fig. 6.2 illustrates the logic generated. This direct translation couples transactions in the target implementation (with, for example, logic wires), and thus may induce undesirable synthesis constraints. In the case that the transactions exist within different domains, this can affect performance and timing closure.



*Closure Condition:*

(E or NotCreated(tB2)) and (G or NotCreated(tA2))

Figure 6.4: Constructing the condition under which Parent can be closed, demonstrating how conditional tokens may terminate paths and must be accounted for.

The third approach generates *counter-tokens* or *anti-tokens* to pass transaction control state. Counter tokens are created at every conditional token creation – if the designed token is not created, then the counter token is created. A latency-tolerant, timing/locale decoupling signal now implements the same logic – that is, it replaces AND with JOIN and OR with SELECT nodes.

Algorithm 6.1 lists pseudo-code for constructing the closure condition for a parent transaction with child transactions. It traverses the local child transaction network, starting with the “last” children (those without forward dependencies), first traversing backwards. It then visits each child in forward topological order: nodes’ predecessors are processed before the node itself is processed. As it visits each transaction, it takes note of conditional tokens. If it is possible for the child transaction to *not* create a token, then that is a potentially *closing* transaction since it could terminate the path of execution. At a JOIN node, the algorithm

---

**Algorithm 6.1** Closure condition construction algorithm for a parent transaction

---

```
1 def CONSTRUCTCLOSURE(transaction parent):
2     condition = True
3     independent-children = {all children without forward transaction
4         dependencies}
5     foreach child in independent-children:
6         condition = condition AND CONSTRUCT(parent, child)
7     return condition
8
9 def CONSTRUCT(transaction parent, child-node):
10    if child-node has already been visited:
11        return child-node.condition
12    if child-node is FORK:
13        condition = False
14        foreach predecessor P of child-node:
15            condition = condition OR CONSTRUCT(parent, P)
16    else if child-node is SELECT:
17        condition = True
18        foreach predecessor P of child-node:
19            condition = condition AND CONSTRUCT(parent, P)
20    else:
21        condition = False
22        foreach incoming token in child-node's guard:
23            condition = condition OR CONSTRUCT(parent, token-source)
24            if token.is-conditional:
25                condition = condition OR NotCreated(token)
26        foreach token created by child-node:
27            if token is conditional:
28                token.is-conditional = True
29    child-node.condition = condition
30    return condition
```

determines the condition under which execution cannot continue; this will occur if *any* of the incoming paths terminate. Its closure condition is the disjunction of all of its incoming paths' closure conditions. For SELECT nodes, on the other hand, execution can only stop at the node if *none* of its tokens are created. The conjunction of incoming conditions forms the node's closure condition. Since this algorithm visits each child transaction once, run-time is linear with the total number of transactions in the design.

Fig. 6.4 illustrates an example of closure condition generation. Below is a step-by-step runthrough of the algorithm. It starts from the transactions with no forward dependencies, transactions E and G. Starting down the E path, it visits predecessor C, which runs unconditionally.

**Tracing the Closure Construction Algorithm** Fig. 6.5 traces closure construction for the transaction hierarchy listed in fig. 6.1. Each colored box represents a recursive dive. As it visits each transaction, it analyzes conditional tokens and incrementally constructs the closure condition. The return values represent the net closure condition for a given node's predecessors. So, for instance, at node B, the return value from its recursive call is the total closure condition for all of B's predecessors (in this case, just A).

## 6.2 Race Condition Detection

A new specification language brings with it the burden to provide verification scaffolding to ensure correct, intended application behavior. Early in the seman-

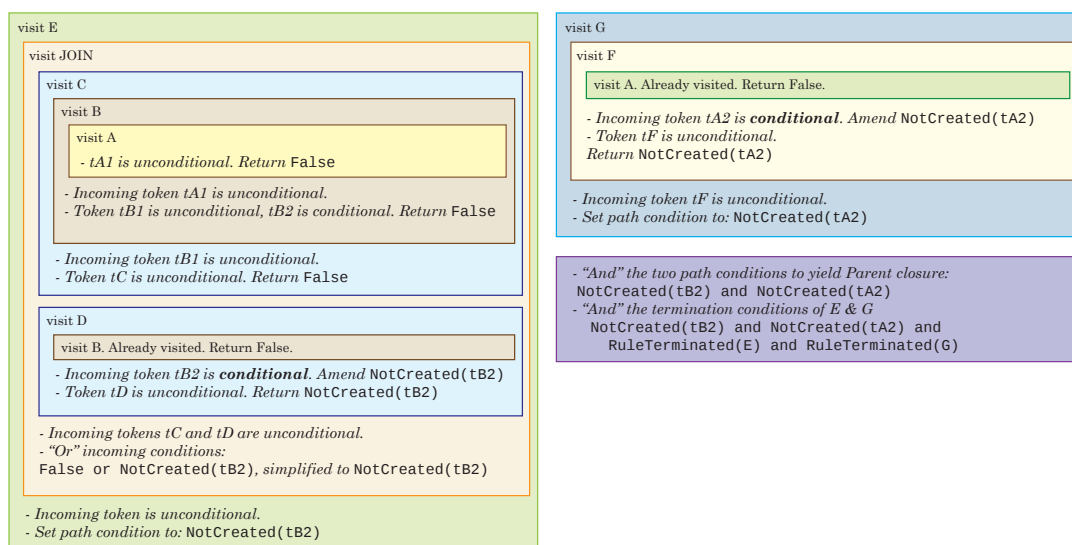

Figure 6.5: A trace of the closure algorithm

tic/language design process, it became clear that latency tolerance coupled with concurrency can quickly lead to correctness challenges. If any two transactions share information, and that information is written in an unexpected order, it may lead to starvation or deadlock. Consider transaction A and B, which both write a variable  $x$ . They execute concurrently and may write  $x$  in either the orders (A. $x$ , B. $x$ ) or (B. $x$ , A. $x$ ). A third transaction C is then executed, which conditionally creates a token  $tC$  based on the value of  $x$ . While this scenario is obvious to the designer, as a design gets increasingly complex, it may not be as clear cut. For instance, A and B may be deep hierarchies or rule instances where the lower child is committing a new value of  $x$ .

This scenario underpins the reasons why the model is transactional, and specifically, why it is locally atomic in its write ordering (e.g. concurrent transactions will choose an order to write – their writes will not overlap). The compiler pro-

vides fast access to potential conflicts, alleviating the difficulties in finding, let alone reproducing, concurrency bugs.

### 6.2.1 Mutually Concurrent Sets

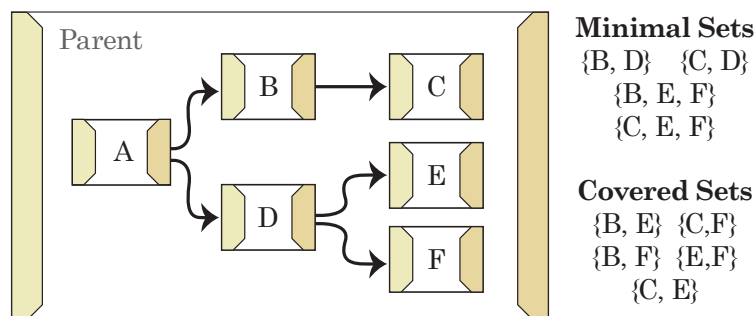

Figure 6.6: Possible concurrent transactions captured in sets. Every covered set is a strict subset of one of the minimal sets. Minimal sets are used for CCR analysis, while the both set types are used in race condition detection (if they commit to the same variables).

A prerequisite for detecting potential race conditions is to determine the sets of potentially overlapping transactions. A straightforward bookkeeping method using *Mutually Concurrent Sets* allows rapid detection in a scalable way. In general, determining these sets on a flat graph would require exponential time; for well-formed hierarchies, however, the runtime is pseudolinear, e.g. the linear component of tree traversal eclipses the local exponential component since the exponent of small numbers is insignificant. Each parent rule manages its overlapping children then compares those sets against the variables they write. If there

**Algorithm 6.2** Calculate pairs of potentially mutually concurrent child transactions.

```
1 Precondition: dep_matrix initialized to NORELATION
2 def DETERMINEMUTUALCONCURRENCY(transaction, path):
3     dep_matrix[transaction][transaction] = NODECISION
4     if transaction in path: return
5     foreach t in path:
6         if dep_matrix[transaction][t] != DIRECTDEP:
7             dep_matrix[transaction][t] = INDIRECTDEP
8         if dep_matrix[t][transaction] != DIRECTDEP:
9             dep_matrix[t][transaction] = INDIRECTDEP
10    path.add(transaction)
11    foreach t in forward-dependencies(transaction):
12        dep_matrix[transaction][t] = INDIRECTDEP
13        dep_matrix[t][transaction] = INDIRECTDEP
14        DETERMINEMUTUALCONCURRENCY(t, path)
15    path.remove(transaction)
```

---

are any transactions writing to the same variable in varying order, the compiler reports the transactions, the variable, and traces the respective assign statements.

### 6.2.2 Dependency Classifier Matrix

The first step is to traverse the local child dependency graph and construct a dependency classifier matrix. This will indicate, for every pair of children, whether the children have no relationship, a direct dependency, or an indirect dependency. The pseudo-code is listed in alg. 6.2. Once these relationships are identified, it proceeds to set minimal set construction.



**Algorithm 6.3** Construct minimal mutually concurrent sets.

---

```
1 Precondition: dep_matrix is correctly populated
2 def CONSTRUCTCONCURRENTSETS(transaction, dep_matrix):
3     concurrent-sets = {} # set of sets
4     foreach child in transaction.child-rules:
5         foreach other in {transaction.child-rules - child}:
6             if dep_matrix[child][other] == NORELATION:
7                 foreach S in concurrent-sets:
8                     if other is mutually concurrent with all members of S:
9                         S.add(other)
10                if other was not added to any set:
11                    concurrent-sets.add({child, other})
```

---

### 6.2.3 Mutual Concurrent Set Construction

The dependency classifier matrix identifies relationships between pairs of rules. To minimize the amount of checks required in race conditions (and therefore keep the runtime bounded), a heuristic collects minimal sets of potentially concurrent transactions. The algorithm is listed in alg. 6.3. It maintains a collection of sets that it has constructed so far. For a given transaction's child dependency network, it analyzes the dependency classifier matrix to identify all pairs of child transactions that may run concurrently. For a given transaction, if there exists a set that the transaction is completely mutually concurrent with, then this transaction becomes a member of that set. Otherwise, a new set is formed.

Runtime of this algorithm is  $N^2M$ , for  $N$  number of child transactions and  $M$  mutually concurrent sets. However, as discussed in the next section, the average number of children is low, and thus cubic growth effectively appears as a constant scale factor.

## 6.2.4 Performance

Limited-child hierarchy is key to effectively linear runtime; Average Number of Transactions per Parent (ANTP) is an approximate metric describing relative system “flatness.”

**Definition 6.1.** *Average Number of Transactions per Parent (ANTP)* is the mean of the number of child nodes for every transaction in the system.

$$ANTP(S) = \frac{1}{N} \sum_{T \in S} C(T_i)$$

where  $N$  is the total number of transactions in system  $S$ , and  $C(T)$  is the number of children in transaction  $T$ .

Fig. 6.8 demonstrates effectively linear (*pseudolinear*) runtime for common use of the model – i.e. hierarchies with reasonably low ANTP. In the worst case, runtime is quadratic with the local number of transactions (the immediate child transactions). However, the algorithm uses a path traversal mixed with a set-membership test that scales with path length. Generally speaking, lower ANTP correlates to shorter path lengths – the longest path is at most the number of local nodes.

Random transaction hierarchies of different sizes were generated using a hierarchy construction heuristic. Hierarchies with varying average number of child per parent transaction (ANTP) are binned into ranges  $A(0, 50)$ ,  $A(100, 150)$ ,  $A(150, 200)$ , and  $A(200, 250)$ . Note that  $A(50, 100)$  yielded similar results to  $A(0, 50)$  and is omitted. Fig. 6.7 illustrates the overhead incurred from constructing mutual concurrency graphs with large average child counts. The runtime grows

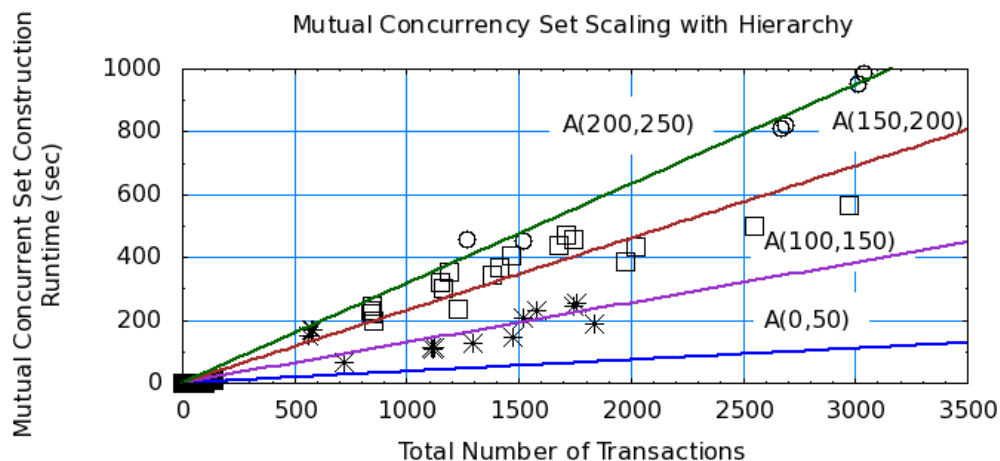

Figure 6.7: Mutual concurrency scaling with different hierarchy depth. “A” indicates the range for ANTP – the average number of transactions per parent. “A(0,50)” means hierarchies with ANTP between 0 and 50.

dramatically as ANTP increases. This is expected – as ANTP increases, the hierarchy disappears, and the algorithm experiences expected close-to-exponential growth.

## 6.2.5 Isolating and Reporting Race Conditions

As discussed in 3.3.7, this model has a high potential for race conditions. The responsibility of resolving race conditions is left to designers, as they have a better sense of intended behavior. Using mutually concurrent sets, the tool simply performs set intersection operations on the sets of variables written by concurrent transactions.

Since set intersection runs in linear time, race condition detection itself is linear with the total number of transactions (shown in fig. 6.9).

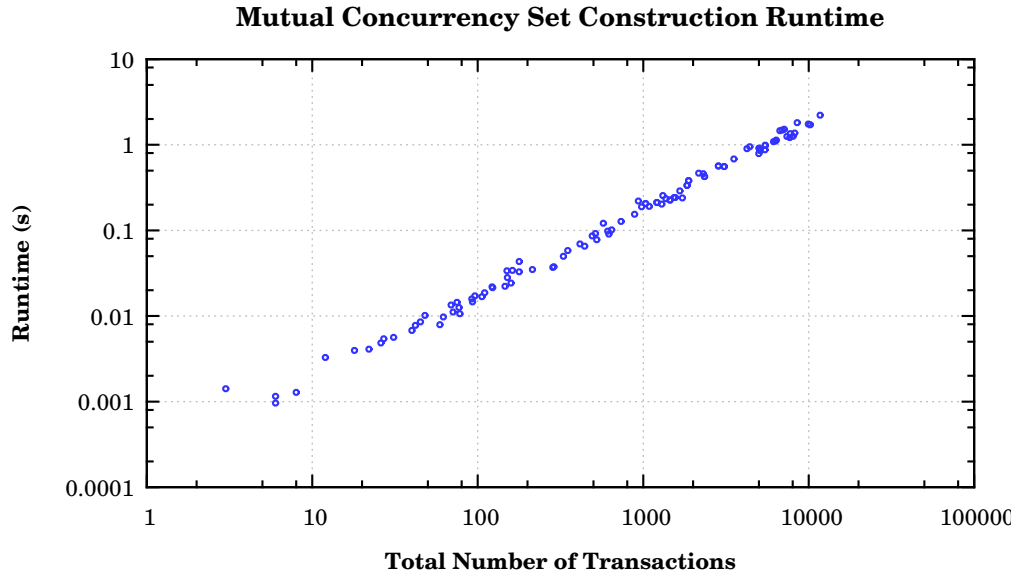

Figure 6.8: Mutual concurrency set construction runtime.

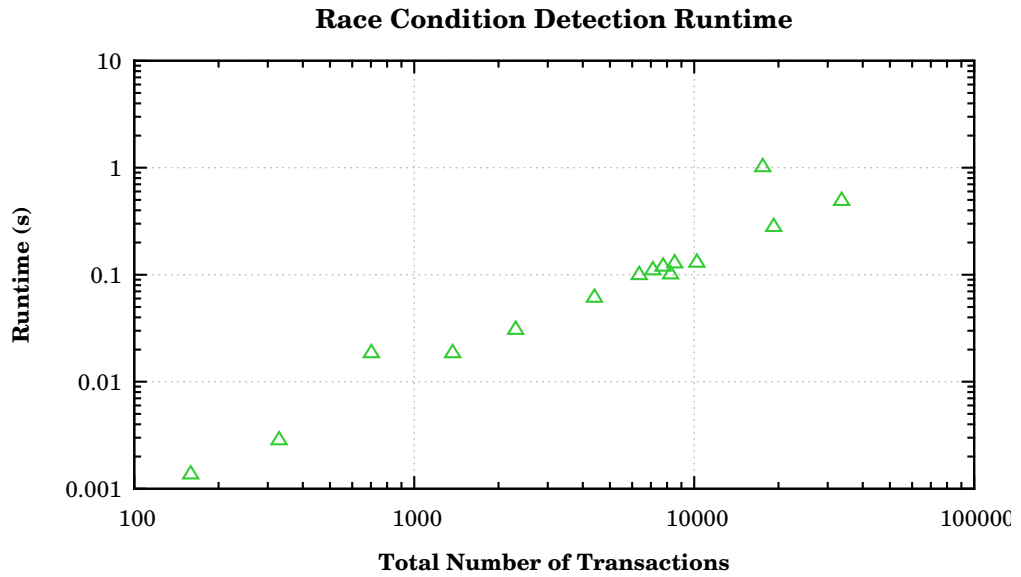

Figure 6.9: Race condition detection scaling.

**Algorithm 6.4** Use the dependency classifier matrix to report potential race conditions.

```
1 for i = 0 to N - 1:
2   for j = 0 to N - 1:
3     if already checked (i,j): skip iteration
4     if dep_matrix[i][j] is not NORELATION:
5       A = variables-written(T[i])
6       B = variables-written(T[j])
7       for variable in set-intersect(A, B):
8         report-conflict(variable, T[i], T[j])
```

**False Positives** The reporting mechanism is conservative – it reports all possible concurrent data interactions. Designers may provide a list of “acknowledged” conflicts, thus avoiding unnecessarily verbose reporting. To further cull the list, the compiler leverages information it gathers from closure mechanism synthesis. The closure logic classifies tokens based on their conditions. If the conditions are mutually exclusive (tagged as such from conditional block structure), then the dependency classifier matrix is updated accordingly.

In the following code, for instance, variable `y` is not reported as conflicting; the compiler statically determines that tokens `tA` and `tB` are mutually exclusive and thus their corresponding forward rules are removed from mutually concurrent sets:

```
1 rule T:
2   if x > 5:
3     create tA
4   else:
5     create tB
6 rule A(tA):
7   y = 1
8 rule B(tB):
9   y = 2
```

## 6.3 Conversion into Existing Semantic Models

The hierarchical transactional model is a unifying model in the sense that it translates to existing data and execution models in a way that is sensible and appropriate for the target domain. In the hardware high-level synthesis field, control/data-flow and pure data-flow graphs are ubiquitous. By translating hierarchical transactions into these models, synthesis tools can leverage a diverse spectrum of synthesis solutions. First, a method of mapping into pure functions is presented (covering straight logic-level synthesis), followed by a control/data-flow conversion technique. Finally, iterator to data-flow conversion is presented (with a novel clustering and synthesis heuristic detailed in Chapter 8).

### 6.3.1 Transactions to Pure Functions

Data and control mobility means transactions are purely functional – they do not make any changes to state outside of their local context. Therefore, any transaction sub-tree can be converted into a strictly combinatorial and arithmetic expression. In the special case of iterators, they are elaborated and unrolled to form the respective functional nodes.

This process requires an algorithm to select one execution path from the family of possible executions, essentially resolving any concurrent reads/writes by assigning variables a unique name. The general flow is as follows, for rule  $R_0$ :

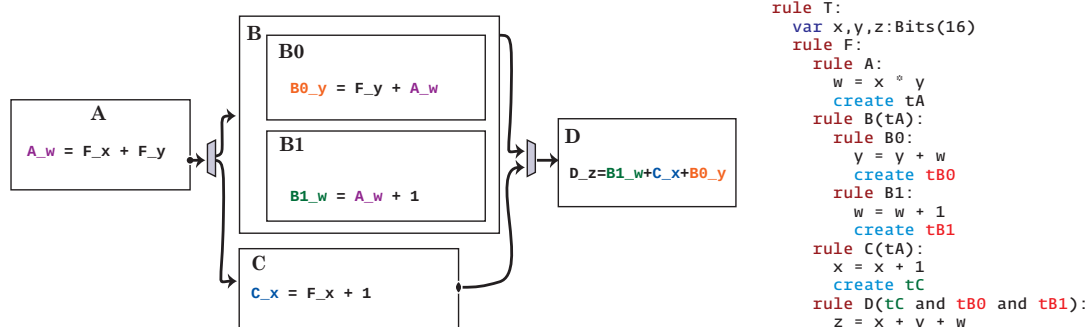

Figure 6.10: Hierarchical transactions to pure function example.

- For all variables read in by  $R_0$ , create source edges
- Visit each child rule in topological order
  - For every input to the child, resolve the source of information by tracing all of the writes thus far:
    - \* If the variable has not been written by this rule, then its source is the value that was read in by  $R_0$
  - For every variable written by the child, create a new edge labeled with the child rule identifier and variable name. Store this information for the next sets of rules

The process is repeated hierarchically. At lower hierarchies, the algorithm must climb up the local sub-tree to resolve a variable's source, ultimately falling back to the top-level rule's input. For example, if rule  $R_0$  contained child  $C_0$  which itself contained  $D_0$ , and  $D_0$  read a variable value that has not been written by either  $R_0$  or  $C_0$ , then it would fall back to the value read in by  $R_0$  (from *its* parent).

Fig. 6.10 illustrates one possible execution of the conversion algorithm. It assumes that  $F_w$ ,  $F_x$ ,  $F_y$ , and  $F_z$  exist, and represent the values read-in by rule F. At each rule it visits, the algorithm traces the source information represented by a given variable. Once each rule has been visited, it performs a final look-up for each variable. If the variable was written internally, the new value overrides the input value. Otherwise, it falls back to the value read-in at the start. It then iteratively substitutes internal values until the final equations are dependent only on the initial inputs read in. The final equations for each of  $w$ ,  $x$ ,  $y$ , and  $z$  are presented:

1	w:	$B1_w = A_w + 1$
2		$= (F_x + F_y) + 1$
3	x:	$C_x = F_x + 1$
4	y:	$BO_y = F_y + A_w$
5		$= F_y + F_x + F_y$
6	z:	$D_z = B1_w + C_x + BO_y$
7		$= (A_w + 1) + (F_x + 1) + (F_y + A_w)$
8		$= ((F_x + F_y) + 1) + (F_x + 1) + (F_y + (F_x + F_y))$

Note that each final equations are only dependent on the values read-in.

Once the pure function is constructed, it can be translated directly into RTL. For more complicated pipelining support, sec. 6.4 outlines a method to convert transactions into control/data-flow graphs. The same method addresses iterators, as they are better suited to CDFGs than pure functions.

## 6.4 Transactions to Control/Data-Flow Graphs

The usefulness of the transaction model is enhanced by its ability to map into many existing approaches. CDFGs and task graphs are the most common application representation model for existing cosynthesis work, and thus reducing



a transaction representation into a data-flow graph grants access to these tools. Translation to control/data-flow graph is very similar to pure function conversion, with the exception that arithmetic nodes are instantiated instead of functions. In fact, pure functions and CDFGs are isomorphic representations of the same behavior. The primary benefit with direct CDFG representation is the availability of scheduling tools and their ability to convert iterators efficiently. While it is possible to create pure functions from iterators, it would lead to very large functions.

One key point here is that transaction data copying allows this process to occur without requiring arbitration or data coherence management. It simply selects a subset of the valid executions and replaces copying by relabeling state. This procedure removes the copying semantic; however, it should be noted that the existence of encapsulated state fundamentally allows an easy and straightforward conversion. The same applies to hierarchy – at any scale, the heuristic can flatten the hierarchy into a graph. This allows the synthesis tool to determine the appropriate granularity for conversion.

Consider the following example:

```
1 rule Top<-(w, x, y, z):
2 var m, n, p, q: Bits(16)
3   rule A:
4     m = x * y
5     p = w * z
6     create tA
7   rule B(tA):
8     rule B0:
9       n = p + x
10      create tB0
11     rule B1(tB0):
12       q = m + y
13       if m > n:
14         create tB1
15   rule C(tA):
16     p = m + x
17   rule D(tB1):
18     q = q + 1
```

As is the procedure with pure functions, the first step is to rename variables according to their source. All of the inputs and outputs are collected, and edges are generated for each.

1. First step is to rewrite all of the variable names and assign nodes – at this stage, the tool will effectively select a subset of possible executions. By naming variables, it selects the source rule, even if another rule may write that value. For instance, rule **C** uses **A**'s copy of **m**.
2. Rewrite each rule's ID. Create edges for every variable read-in and written out.

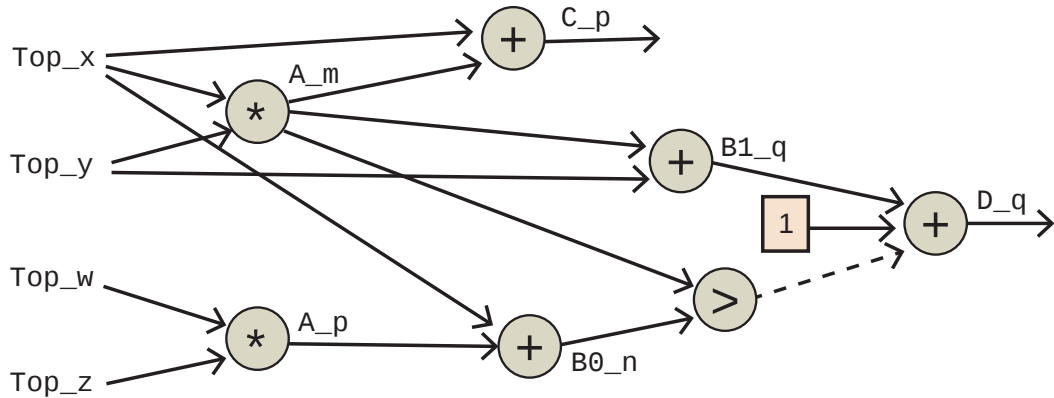

Figure 6.11: Hierarchical Transactions to CDFG Example. Solid lines are data edges. Dotted lines are control edges.

The resulting example becomes:

```

1 rule Top<-(Top_w, Top_x, Top_y, Top_z):
2   rule A:
3     A_m = Top_x * Top_y [node 0]
4     A_p = Top_w * Top_z [node 1]
5     create tA
6   rule B(tA):
7     rule B0:
8       B0_n = A_p + Top_x [node 2]
9       create tB0
10    rule B1(tB0):
11      B1_q = A_m + Top_y [node 3]
12      if A_m > B0_n: [control node 4]
13        create tB1
14  rule C(tA):
15    C_p = A_m + Top_x [node 5]
16  rule D(tB1):
17    D_q = B1_q + 1 [node 6]

```

Fig. 6.11 illustrates the result of creating a CDFG from the above example – solid lines represent operands passing between operations while dotted edges are purely control (and conditionally determine flow). The token tB1 is created conditionally based on the difference between m and n – a conditional edge is created between the comparison operator and the subsequent addition.

### 6.4.1 Flow-graphs from Iterators

While conversion from iterators to CDFGs makes the representation amenable to existing technologies, it does so at the cost of lost symmetry information. There is high potential for leveraging symmetry in code generation as a compaction method for reducing control overhead, particularly when synthesizing addressing/indexing logic. For example, a system with an accelerating arithmetic pipeline would need input and output addresses for every operand, along with a method to represent data dependencies. With symmetry information, this control information can be codified into a state machine index generator optimized for a particular architectural target.

That said, there are still benefits to sourcing CDFGs from iterators. First and foremost, iterators make guarantees about the scope and access of information. They will not result in random graphs, but rather, well-structured, well-defined graphs.

The actual translation from transactions containing iterators into CDFGs is precisely the algorithm above, with an added iterator unrolling step. The system first converts the body of the iterator; it constructs a local CDFG and replicates this set for each iteration. For every iterating variable, the compiler queries its respective iterators (e.g. if they are composed or nested iterators) to yield the requested data.

## **6.4.2 Software Scheduling**

Once a portion of the application is targeted at the software domain, the synthesis tool can selectively flatten subsets of the design and apply traditional, well-known software scheduling techniques. In a multiprocessing context, transactional boundaries resolve the problem of managing shared state – all of the interaction is well-defined, and potential race conditions are exposed at the abstract model level. There are software-specific features that can guide efficient realization: a large, cached memory is useful for storing dependency information for dynamically dispatching transaction executions. The software synthesizer may leverage reference locality to better use available caching. If the synthesis tool is aware of cache sizing and structure, it can accordingly adjust software/hardware partitioning to make (near-)optimal utility of the cache.

## Chapter 7

# Control-Dominant Application Study

Real-world hardware/software systems exhibit a mix of control- and data-dominated components. This chapter demonstrates the control end of the spectrum: a study into the specification of a microprocessor, complete with internal concurrent tasks and complex control decisions. The emphasis is on exercising the language and semantic model – in practice, a processor may be suitable as a cosynthesis application for simulation speed-up. For instance, in the early stages of a microprocessor instruction architecture design, a field-programmable gate array (FPGA) can leverage hardware accelerator to rapidly simulate applications, exposing potential pipeline bottlenecks and critical instructions.

More importantly, if the language can express a processor, then it is rich enough to express any equally complex application (including the type of mixed reactive/high performance applications commonly targeted towards embedded systems). The primary goals of this study is to evaluate feasible execution of

a complex design expressed as hierarchical transactions, and expose useful properties from an exercised model.

## 7.1 The MSP430 Microprocessor

Texas Instrument's MSP430 [81] is a popular ultra low power microprocessor commonly used for power-constrained embedded applications. Its instruction set architecture (ISA) is minimal but complete. The HTL realization is based on Greg Hoover's PyTDL MSP430 implementation [48], extended with hierarchy and covering the complete ISA.

## 7.2 Processor Specification

When approaching this problem, the primary focus is on expressing the interface-level functionality, completely irrespective of timing details. The design is an abstracted implementation of a pipelined architecture – functionally correct, but latency tolerant. It runs valid MSP430 executables (generated from a GCC-based cross compiler).

The instruction set contains standard addition and subtraction operators – a multiplier is accessible through memory mapped I/O. Decoding and executing instructions are expressed directly in rules. Both the register file (containing 16 registers), and memory are instances of the `Addressable` built-in library type, allowing indexed behavior. The topmost rule is a testbench environment, containing the entire application's behavior within a single rule tree. Instructions

and status registers are object instances of specialized classes – the `Instruction` class contains functional rules for decoding the operation. The results in clean, readable code.

The following sections demonstrate a small portion of the specification (the decoding logic). The full specification is available in Appendix B.2.

### 7.2.1 Decoding

The following decodes an instruction, creating appropriate conditional tokens depending on the type of operation.

```
1 var src_op, dest_op: Bits(16)
2 var src_pc_offset, dest_pc_offset: Bits(2)
3
4 var src, dest: Bits(4)
5 var smode, dmode: Bits(2)
6
7 rule Decode:
8     rule DetermineType:
9         print "Instruction value: ", hex(instr.v)
10        pc_offset = 1
11        if instr.is_jump():
12            print "  Jump operation"
13            create tExecuteJump
14        elif instr.is_single():
15            print "  Single operation"
16            create tDecodeSingle
17        elif instr.is_double():
18            print "  Double operation"
19            create tDecodeDouble
20        else:
21            create tDecodeError
22
23    rule DecodeSingle(tDecodeSingle):
24        src = instr.single_dsreg()
25        smode = instr.single_ad()
26
27        if not instr.opRETI():
28            create tGetSourceOperand
29        else:
30            # For RETI instructions, we just execute them
                directly. We just pretend
```



```
31         # that the source operation was completed by
           creating the token here.
32         src_op = 0
33         src_pc_offset = 1
34         create tSourceReady
35
36     rule DecodeDouble(tDecodeDouble):
37         src = instr.double_sreg()
38         smode = instr.double_as()
39         create tGetSourceOperand
40
41         if instr.opMOV():
42             create tDecodeMOV
43         else:
44             dest = instr.double_dreg()
45             dmode = instr.double_ad()
46             create tGetDestOperand
47
48     rule DecodeMOV(tDecodeMOV):
49         # If it's a MOV instruction, we do not need to read
           the destination
50         # so we just create the token here.
51         if smode == 1:
52             dest_pc_offset = 1
53         else:
54             dest_pc_offset = 0
55         dest_op = 0
56         create tDestReady
57
58 # end rule Decode
```

Note that the print statements are purely for simulation. Recall that all rules are atomic – in the case that there are multiple statements in the rule, they run concurrently.

The `DecodeSingle` and `DecodeDouble` paths are mutually exclusive, conditional on the type of instruction. The token semantic lends itself to a flexible method of communicating control that particularly simplifies error conditions. On decode error, the `tDecodeError` token is created – the token climbs the hierarchy (as the respective transactions commit) until it is consumed by logic to manage the decode error.

The processor dispatches concurrent paths to retrieve its source operands (including the constant generator, memory, or register). It further sets up the destination operand. Execution is distributed: jump instructions, arithmetic operations, and memory read/writes are all rule sub-trees. Finally, write-back occurs after execution, ending the instruction stream.

## 7.3 Race Condition Detection

The race condition detection algorithm from sec. 6.2.5 was applied to the processor. Since the heuristic is conservative, it reported over 40 situations where variables may be overwritten concurrently. The list was culled based on designer knowledge of exclusive execution paths down to eight potential issues. After analyzing the reads and writes, two serious race conditions were exposed, both related to off-by-one counting in the calculation of the program counter. The entire process of detecting and correcting race conditions took less than five minutes – there was no additional overhead in specifying a separate formal model or requiring deep execution analysis. The direct codification of shared state allowed the compiler to quickly and efficiently report these bugs to the designer.

### 7.3.1 The Original Problem

In the first version of the processor specification a `pc_offset` variable indicated how much to increment the program counter. Initially, no concurrency was exploited, and the rules to retrieve source operands each incremented this off-

set. Once the two paths were made concurrent, however, it exposed the following conflict:

```

1  var pc_offset: Bits(2)
2
3  rule GetSourceOperand(tGetSourceOperand):
4      rule DetermineSourceAddressing:
5          pc_offset = 0
6      rule SourceAbsolute(tSourceIsAbsolute):
7          pc_offset = pc_offset + 1
8      rule SourceIndexed(tSourceIsIndexed):
9          pc_offset = pc_offset + 1
10     rule SourceIndirect(tSourceIsIndirect):
11         pc_offset = pc_offset + 1
12     rule SourceImmediate(tSourceIsImmediate):
13         pc_offset = pc_offset + 1
14     # Eventually creates tDestReady
15
16     rule GetDestOperand(tGetDestOperand):
17         rule DetermineDestAddressing:
18             pc_offset = 0
19         rule DestAbsolute(tDestIsAbsolute):
20             pc_offset = pc_offset + 1
21         rule DestIndexed(tDestIsIndexed):
22             pc_offset = pc_offset + 1
23         rule DestIndirect(tDestIsIndirect):
24             pc_offset = pc_offset + 1
25         rule DestImmediate(tDestIsImmediate):
26             pc_offset = pc_offset + 1
27         # Eventually creates tSourceReady
28
29     # an intermediate rule waits for tSourceReady and tDestReady
30     # and creates tInstructionDone
31
32     rule InstructionDone(tInstructionDone):
33         pc = pc + pc_offset # Here's where the two paths report the
                             # wrong PC offset

```

Once the problem was identified, the solution was simple:

```

1 rule GetSourceOperand(tGetSourceOperand):
2   rule DetermineSourceAddressing:
3     src_pc_offset = 0
4   rule SourceAbsolute(tSourceIsAbsolute):
5     src_pc_offset = src_pc_offset + 1
6   rule SourceIndexed(tSourceIsIndexed):
7     src_pc_offset = src_pc_offset + 1
8   rule SourceIndirect(tSourceIsIndirect):
9     src_pc_offset = src_pc_offset + 1
10  rule SourceImmediate(tSourceIsImmediate):
11    src_pc_offset = src_pc_offset + 1
12  # Eventually creates tSourceReady
13
14 rule GetDestOperand(tGetDestOperand):
15   rule DetermineDestAddressing:
16     dest_pc_offset = 0
17   rule DestAbsolute(tDestIsAbsolute):
18     dest_pc_offset = dest_pc_offset + 1
19   rule DestIndexed(tDestIsIndexed):
20     dest_pc_offset = dest_pc_offset + 1
21   rule DestIndirect(tDestIsIndirect):
22     dest_pc_offset = dest_pc_offset + 1
23   rule DestImmediate(tDestIsImmediate):
24     dest_pc_offset = dest_pc_offset + 1
25   # Eventually creates tDestReady
26
27 rule Execute(tSourceReady and tDestReady):
28
29   rule DetermineExecutionType:
30     # first combine pc offsets
31     pc_offset = pc_offset + dest_pc_offset + src_pc_offset

```

**Generalized Model** The primary limitation in race condition detection is indexed data, particularly access to the register file and memory. These situations encounter traditional exponential scaling, as there are few options except comprehensive state exploration. While the specific violating indexes cannot be ascertained at compile time, it does report when transactions attempt to concurrent write to the indexed object. In the worst case, it provides overly conservative bounds.

## 7.4 Transactional Simulator

The MSP430 executed in the behavioral simulator, validating that the architecture was correctly implemented. Simple software applications were written in C and cross-compiled to the MSP430 ISA. These applications were then executed in the transactional simulator (built into the compiler), preserving the token and transactional abstraction. Development time was short, largely because the specification language is concise and clear.

In order to facilitate the register file and memory, an extension was built into the simulator that prevented it from copying either indexable object transactionally. This would have created tremendous memory and performance overheads, hindering simulation speed. Instead, a logging mechanism maintained a trace of reads/writes to the parent memory (trimming overwritten information to keep it small). Any concurrently executing transactions were resolved at commit; if there was a memory conflict between transactions, this information was dynamically reported to the user.

The following example illustrates a situation that the simulator reports. For rule A, the logging mechanism stores a mapping between `memory[1]` and its write value 1. The same happens for rule B – the value 2 is stored for `memory[1]`. Once both transactions commit, the simulator detects a conflict and warns the user.

```
1 rule Top:
2   var memory: Addressable(1024, Bits(16))
3   rule A:
4     rule A0:
5       x = 1
6     rule A1(tA0):
7       memory[x] = 1
8   rule B:
9     memory[1] = 2
```

## 7.5 Direct-to-RTL Realization

Designing new semantic models requires a mix of formal construction and practical realization. Early in the design process, a direct-to-RTL code generator was used to discover any potential execution issues – in fact, this led to the discovery of a closure requirement. The code generator directly implemented transactions in the Verilog Hardware Description Language, including full copying semantic. For the register file and memory, however, the code generator instantiated single instances of both and scheduled around concurrent accesses (for simplicity). While this approach obviates any race conditions related to either indexed storage, it does allow full simulation of the control logic.

The primary insight in direct model realization is verification of closure correctness. The MSP430 implementation contains a significant number of conditional tokens, and therefore conditionally executing transactions. In the gate-level simulation, a compiled C program executed on the RTL MSP430 implementation, covering a reasonable array of instructions. By virtue of complete execution, the model proved to be closed and executable.

## Chapter 8

# High Performance Arithmetic Applications

At the opposite end of the spectrum from control-dominated applications are high-performance, arithmetic-heavy algorithms. This chapter demonstrates a feasible synthesis path for high-performance realizations of arithmetic-heavy application. It presents architectural exploration of matrix multiply, Fast Fourier Transform (FFT), and image convolution examples. The assumption is that lower level model conversion occurs after initial coarse-grained synthesis – i.e. after information flow is grossly organized with a global view of the problem. It leverages encapsulated control and state to reduce a larger problem into a format that has well-known and field-tested solutions without the need to mitigate data coherence at a large scale. The following sections expand upon data-flow methods to include a unique memory capacity-based clustering technique ideal for hardware arithmetic acceleration. This approach scales tremendously, managing graphs up to the million-node scale.

## 8.1 Memory Capacity and Data Motion

Transactional semantics accomplish dual goals of pseudo-linear scalable analysis without sacrificing performance. The latter arises from a decoupling of specification and hard memory constraints. As a result, synthesis has freedom to allocate and bind to complex memory systems.

Capturing data motion costs is critical to efficient heterogeneous implementations – it motivates the design of the hierarchical copying semantic. When approaching synthesis of a very large application, memory capacity constraints will significantly dictate the resultant performance. If there is not enough intermediate, local storage to sufficiently provide operands to arithmetic pipelines, then a scheduler has little choice but to insert bubbles, each of which is a missed opportunity.

Hierarchical transactions allow synthesis tools to easily summarize and isolate subsections of a design without the need for complex and computationally expensive clustering. In fact, clustering a directed graph (say, for data-flow representations) for a very large problem can be difficult: the problem is naturally tightly constrained, as the clusters need to remain acyclic to remain amenable to scheduling.

## 8.2 Problem Setup

The primary target of the high-performance data-flow technique presented is reconfigurable embedded systems containing a microprocessor (either in the fabric or a hard IP block) interfacing with a large, off-chip double data rate



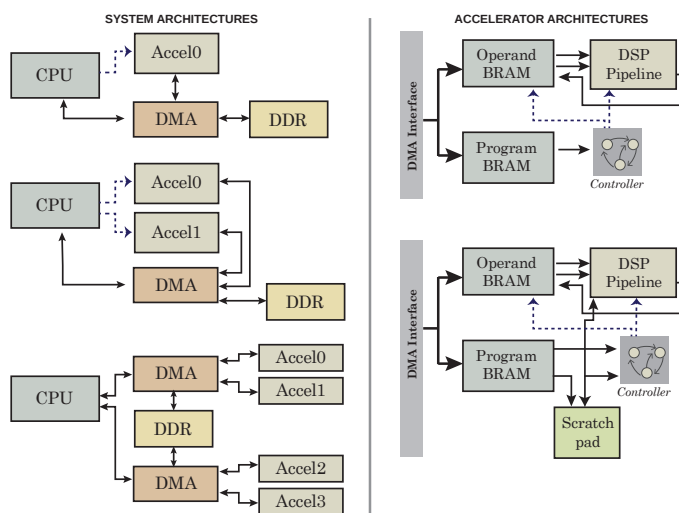

Figure 8.1: Left: System point-to-point architectures with 1, 2, and 4 accelerators. Right: Accelerator without and with scratchpad memory (SPM)

(DDR) memory. The processor runs software that dispatches operand clusters to accelerators through a direct memory access (DMA) controller – that is, the software instructs the DMA to transfer DDR memory directly to and from the accelerators. All of the buses are assumed to be point-to-point to reflect modern ARM-based platforms. Fig. 8.1 illustrates three system architectures and two accelerator architectures.

### 8.2.1 Commercial IP Options

There are a variety of off-the-shelf third party signal processing accelerators for algorithms such as DCT, FFT, and matrix multiply, many of which contain bus interfaces to allow simple software integration. These products are remarkably efficient but are typically targeted as fixed sizes. Applications like FFT and DCT can handle larger problems by composing smaller accelerators (e.g. a 16K-point

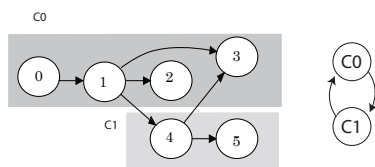

Figure 8.2: Illustration of clustering that can induce cycles

FFT can be composed of  $4 \times 8K$  FFT blocks). However, as the problem grows to very large scales, there are no obvious methods of managing the enormous amount of information that must be exchanged between blocks. Algorithms such as matrix multiply have no choice but to resort to DSPs and custom DSP software. Again, managing the gross motion of data is not straightforward. The approach presented in this chapter accepts designs of any shape. While random graphs may prove less efficient, real-world arithmetic graphs can exploit hardware parallelism due to their local operation scope.

## 8.2.2 Challenges in Digraph Clustering

Clustering a directed graph can lead to a minefield of induced cycles (fig. 8.2) when the cluster graph is generated based on its nodes dependencies. This cannot be directly scheduled as there are coupled dependencies which are unresolvable without violating cluster boundaries. The Kernighan-Lin algorithm [54] approaches this problem with a heuristic that evaluates the net cost of preserving balanced partitions across multiples moves from one partition to another, capturing both the cost of the node itself and the subsequent corrections that make the original move sensible.

Scheduler-driven partitioning proposes a different approach: clustering is performed as part of list scheduling, thus guaranteeing that the clusters themselves can be scheduled at a coarser grain.

### 8.3 Scheduler-Driven Partitioning

To reach high performance arithmetic designs, an implementation strategy is presented based on well-formed data-flow designs generated by iterators. The target platform is a heterogeneous reconfigurable architecture. The primary application space is reconfigurable embedded systems, where there is an opportunity to selectively hardware-accelerate an arithmetic-heavy portion of the application. Its approach partitions a data-flow graph into small clusters that fit into microarchitectures consisting of a program memory, an operand memory, and a pipelined micro-DSP (i.e. a DSP without any control logic), shown in fig. 8.3. The system architecture contains a primary CPU attached to high-speed, high-capacity double-data rate (DDR) memory, along with a selection of accelerators (fig. 8.1). The peripheral has an optional scratchpad memory (SPM) with parameterizable size. A scratchpad memory essentially provides a local operand buffer to exploit reference locality without the overhead of a traditional cache. In essence, it provides a second pair of memory ports to allow maximal use of every computation cycle available.[74]

The first step selects the arithmetic-heavy portion of the application, and constructs a data-flow graph via its iterators. A list scheduler then selects nodes to insert into the DSP pipeline until memory capacity constraints are met, thus

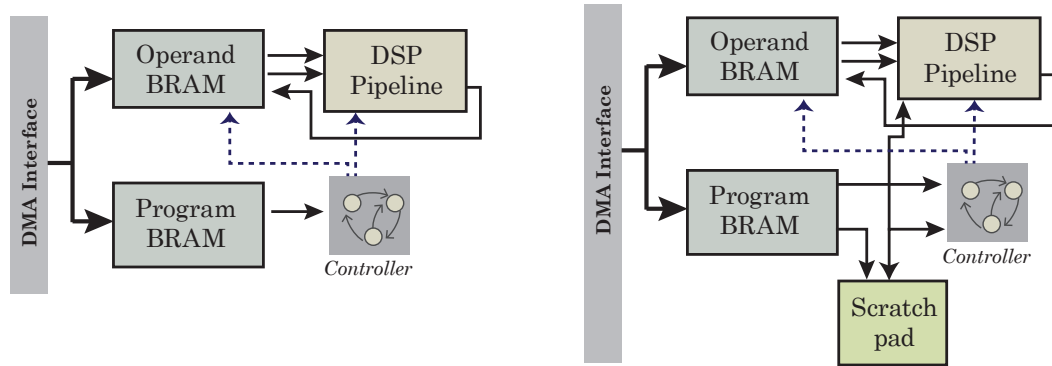

Figure 8.3: Internal architecture for peripheral. The bus provides initial operands and the program. A controller executes this program and uses the local operand block RAM (BRAM) to store intermediate operations. After the program has completed, the controller initiates a transfer to the DMA controller while simultaneously asserting an interrupt for the main CPU. When the DMA is configured in scatter-gather mode, the next set of operations arrives automatically, based on an internal linked list of data copying blocks. The peripheral on the right adds a local scratchpad memory to provide local, higher utility access to operand data.

---

**Algorithm 8.1** List-scheduler based cluster building heuristic

---

```
1: function BUILDCLUSTER(graph, ready-list, bram-size)
2:   populate ready-list with initial nodes from graph
3:   alloc-mgr  $\leftarrow$  AllocationManager()
4:   while graphnot-scheduled do
5:     alloc-space  $\leftarrow$  alloc-mgr.space()
6:     if alloc-space at capacity and ready-list is locked then
7:       exit loop
8:     end if
9:     new-node  $\leftarrow$  ready-list.dequeue(alloc-space)
10:    if new-node is valid then
11:      schedule(new-node)
12:      add fwd deps to ready-list
13:      allocate addresses for new-node
14:    else
15:      wait for pipeline to clear
16:    end if
17:  end while
18:  return schedule, nodes-scheduled
19: end function
```

---

delineating that particular cluster. The global clustering heuristic creates a corresponding cluster node, then continues generating further clusters until all of the nodes have been scheduled and clustered. The ready list for the scheduler must be persistent across different cluster calls, as it maintains the overall scheduler state. A specialized allocation manager assigns memory addresses to the input and output operands as they are available. If there is no operand space remaining, the scheduler first determines if it can wait until the pipeline has cleared. If there are no more operations that can fit within the constraint, it terminates the local run. Pseudocode for the clustering-scale heuristic is shown in alg. 8.1.

---

**Algorithm 8.2** Design partitioner using the cluster building heuristic

---

```
1: function CLUSTERGRAPH(graph, bram-size, bram-count)
2:   compute node priorities
3:   ready-list  $\leftarrow$  ReadyList()
4:   populate ready-list with initial nodes
5:   while ready-list has nodes do
6:     cluster-schedule, nodes-scheduled  $\leftarrow$  BuildCluster(graph, ready-list, bram-size)
7:     clusters.add(new Cluster(nodes-scheduled))
8:   end while
9:   cluster-graph  $\leftarrow$  BuildClusterGraph(clusters)
10:  cluster-schedule  $\leftarrow$  ResourceSchedule(cluster-graph, bram-count)
11: end function
```

---

Once the initial clusters are constructed, the clusters themselves are scheduled to determine total system cost. It factors in bus timing to transfer information to and from the accelerators and accepts a parameter specifying the number of available peripherals. A simple resource-constrained list scheduler is used (since the total number of clusters tends to be relatively small).

### 8.3.1 8-point FFT Clustering Illustration

Consider the scheduler-driven clustering of a small 8-point FFT. Fig. 8.4 illustrates the first phase of the heuristic that gathers individual clusters based on capacity. The image highlights five clusters, and shows the order in which they may be scheduled on the right (one of many valid orderings). In practice, the heuristic will select much larger and deeper clusters; for illustrative purposes, assume a very small capacity constraint. Once the clusters are generated, the cluster dependencies are constructed and the graph is scheduled onto the system. Fig. 8.4 illustrates the resultant cluster graph (based on the FFT's dependencies) and

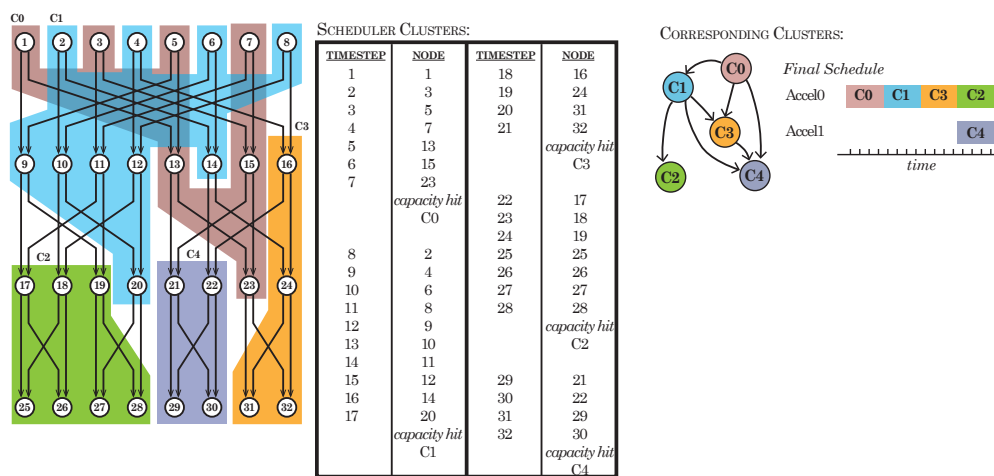

Figure 8.4: Scheduler-driven clustering of FFT with corresponding cluster graph and system-level schedule for FFT

a potential schedule onto an architecture with two accelerators. In this particular example, the second accelerator can only be used 25% of the time; this valuable insight can guide the designer to select the appropriate number of accelerators based on their constraints.

### 8.3.2 Target Algorithms

**Fast Fourier Transform** The Fast Fourier Transform (FFT)[20] is a common signal processing algorithm that transforms a time-varying signal into its frequency components (along the power spectrum). It is a prime candidate for hardware acceleration, as it exhibits a high ratio between computations and data motion. This shape also models similar algorithms such as the Discrete Cosine Transform (DCT) commonly used in multimedia applications.

**Matrix Multiplication** Matrix multiply is a foundational operation underpinning signal processing and control system applications, not to mention graphics, learning, and physical simulation tools. Matrix multiplication has been implemented for any valid matrix shapes, allowing a large variety of linear operations (incidentally including a variant of FFT[32]). The iterator produces a tree reduction for the final sums when computing the linear product of rows and columns.

**Image Convolution** Finally, an image convolution was chained together with both a matrix multiply and FFT to emulate a complex DSP algorithm. This configuration illustrates that the heuristic is agnostic of problem shape, allowing a wide variety of composed iterators.

**Software Pipelining** Software pipelining is the dispatch of independent threads of execution. Issuing multiple independent computational threads (for instance, on different video frames) allows maximal use of hardware parallelism. Computations can overlap with bus transactions, and independent operations fill in otherwise wasted computation cycles. Implementing this in the scheduler involves replicating the cluster graph, then scheduling all of the separate cluster graph copies onto the same system architecture.



## 8.4 Results

This heuristic was applied to a series of FFTs, matrix multiplications, image convolution, and combinations of these to emulate DSP pipelines. The parameters dictating algorithm size (for instance, FFT width, matrix dimensions) were varied to evaluate scaling. The clustering and scheduling heuristics were implemented in Python. Verilog models were written for the accelerating peripheral, including the bus interface logic. The bus cost models reflected a Xilinx Vivado system using DMA Scatter-Gather targeting a Zedboard[90]. All results were generated on a dual-Xeon E5630 server. A tremendous number of valuable architectural configurations were generated automatically – within a single day, over 500 architecture configurations were evaluated, varying BRAM size, SPM size, algorithms, number of accelerators, and software pipeline depth.

### 8.4.1 FFT

The first demonstration is the Fast Fourier Transform (FFT). The scheduler-driven clustering heuristic was applied to FFTs of varying sizes across different local memories. The FFT results are listed in appendix D, listing for given BRAM/accelerator configurations, how long the resultant schedule is, the number of clusters generated, and the heuristic runtime. All results were run on a second-generation 16-thread Intel Core i7 server.

Fig. 8.5 illustrates, for different FFT sizes, the length of the generated schedule versus the size of the accelerator’s BRAM for two accelerators. It is clear that in all cases, there was improvement with added memory capacity; that improvement,

however, is limited (on the order of 6-8%). This is due in large part due to limited memory port access.

**Unexpected BRAM-size Invariance** One of the key insights discovered by this heuristic is the ineffectiveness of larger operand BRAMs. Fig. 8.8 illustrates, for varying BRAM sizes, the effect of scratchpad memory size. For reasonably sized elements (enough to cover a saturated DSP pipeline), the system executes with relatively high utility of the arithmetic units. This is enforced by the dense arithmetic shape of FFT and matrix multiplication which always provide ready operands.

Without understanding how the system actually executes, this result is rather unintuitive. Larger local memories are assumed to correlate with higher performance. Clearly, the specific architectural choices in these accelerators exhibit unexpected cost trade-offs. By rapidly exposing the key architectural effects, the designer can tailor systems with much lower area (due to smaller BRAMs), allowing better use of the remaining programmable fabric.

**Importance of Scratchpad Size** On the other hand, the scratchpad size has a significant effect on performance. Despite a relatively small size, the additional memory ports prove invaluable to ensuring there are new operands at almost every clock cycle. It is safe to conclude that efficient performance for this style of accelerator requires a balance between memory capacity and, perhaps more importantly, memory port resources.

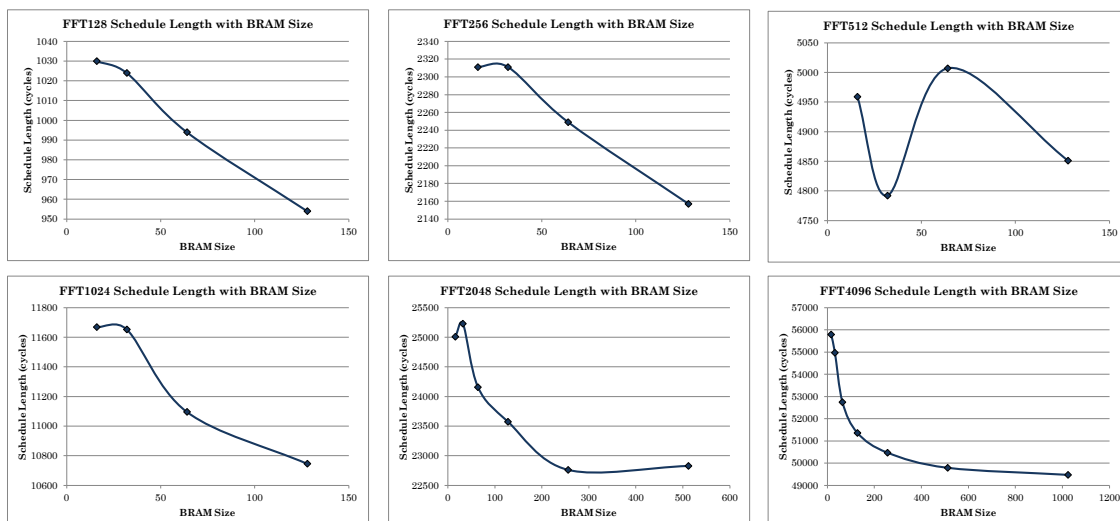

Figure 8.5: FFT total schedule length (including bus transfers) versus size of BRAM for a 2-accelerator architecture.

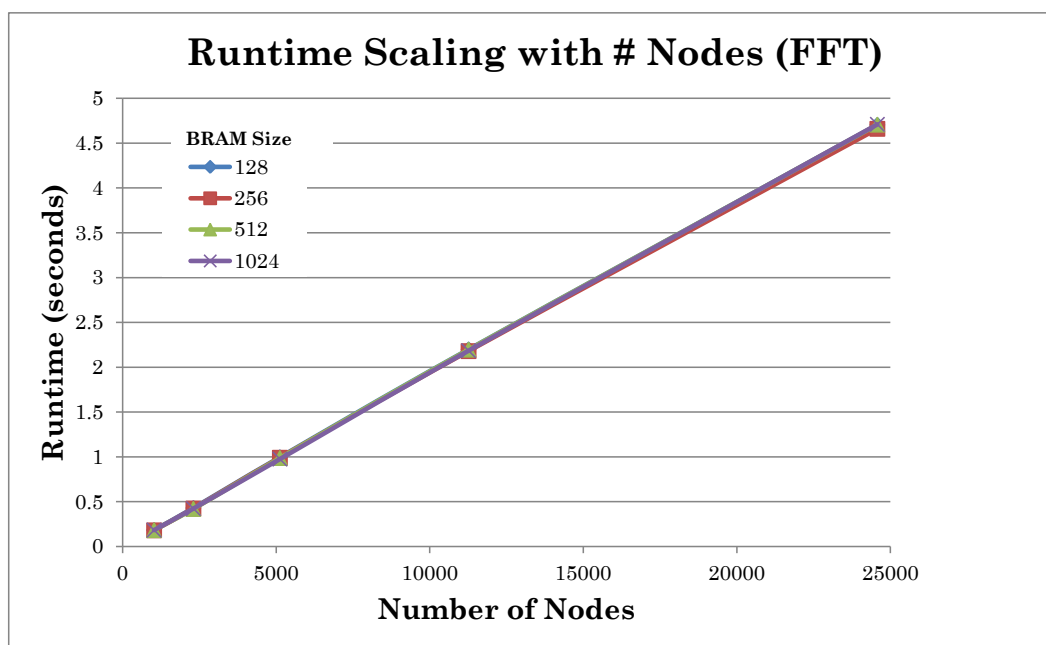

Figure 8.6: Heuristic runtime scaling with increasing node counts on FFT instances.

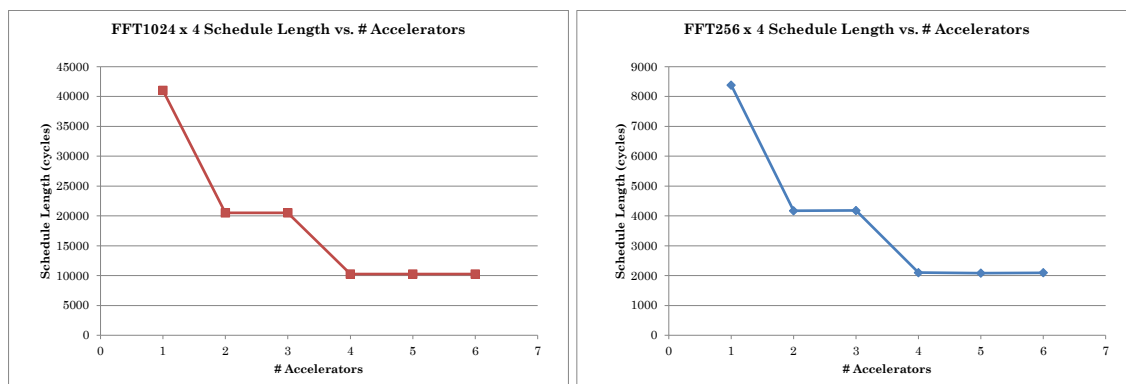

Figure 8.7: For fixed BRAM size, both FFTs of size 1K and 256 exhibited the same shape across different peripheral accelerator configurations.

Fig. 8.6 demonstrates the heuristics scaling with the number of nodes, across different BRAM constraint sizes. As is evident, scaling is linear as the number of nodes increases, irrespective of BRAM size.

## 8.4.2 Matrix Multiplication

The same experiments were run on matrix multiplication – square matrices were multiplied together, across varying matrix sizes and BRAM constraints. Fig. 8.9 demonstrates nearly identical behavior as the FFT – as the BRAM size constraint increases, there is diminishing parallelism due to increased program length.

**Software-pipelined Matrix Multiplication** A matrix multiplication was software pipelined against multiple accelerators. The intuition is that the number of accelerators should correlate to the depth of the software pipelining. Indeed, fig. 8.10 shows this precise behavior. Interestingly enough, for pipeline depths of 7

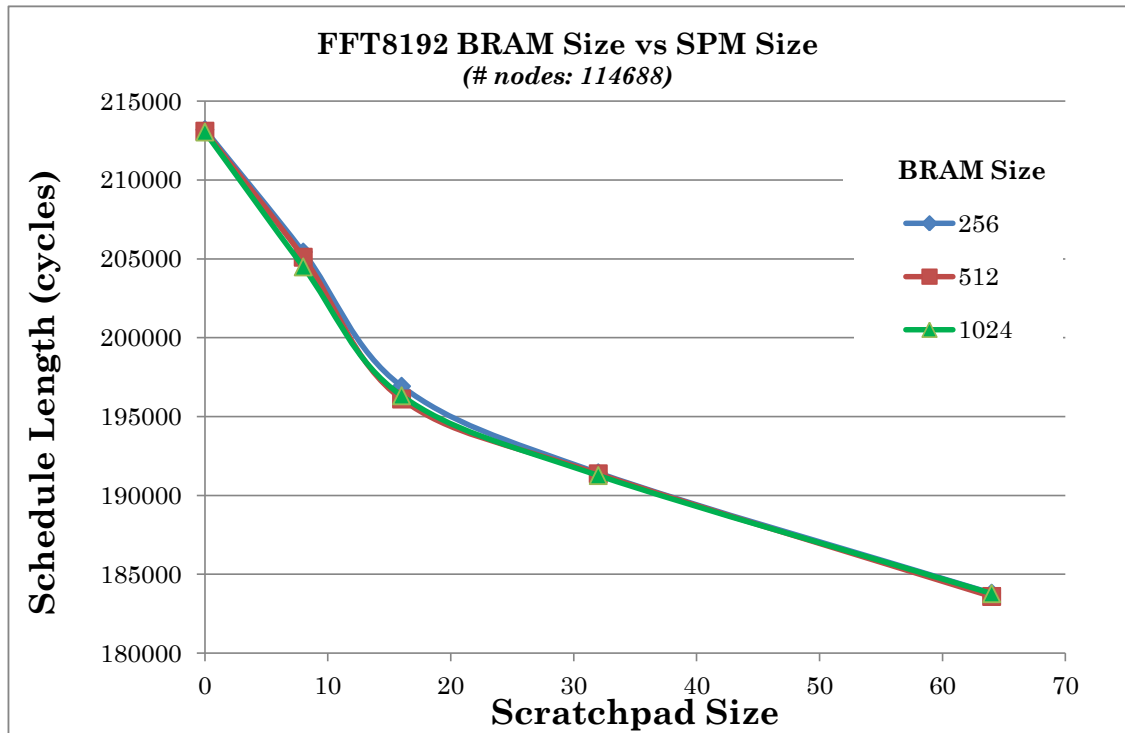

Figure 8.8: Across different BRAM sizes, the SPM size was varied. Clearly, there is little to no improvement with larger BRAM. This correlates to utility limits stemming from a single port constraint.

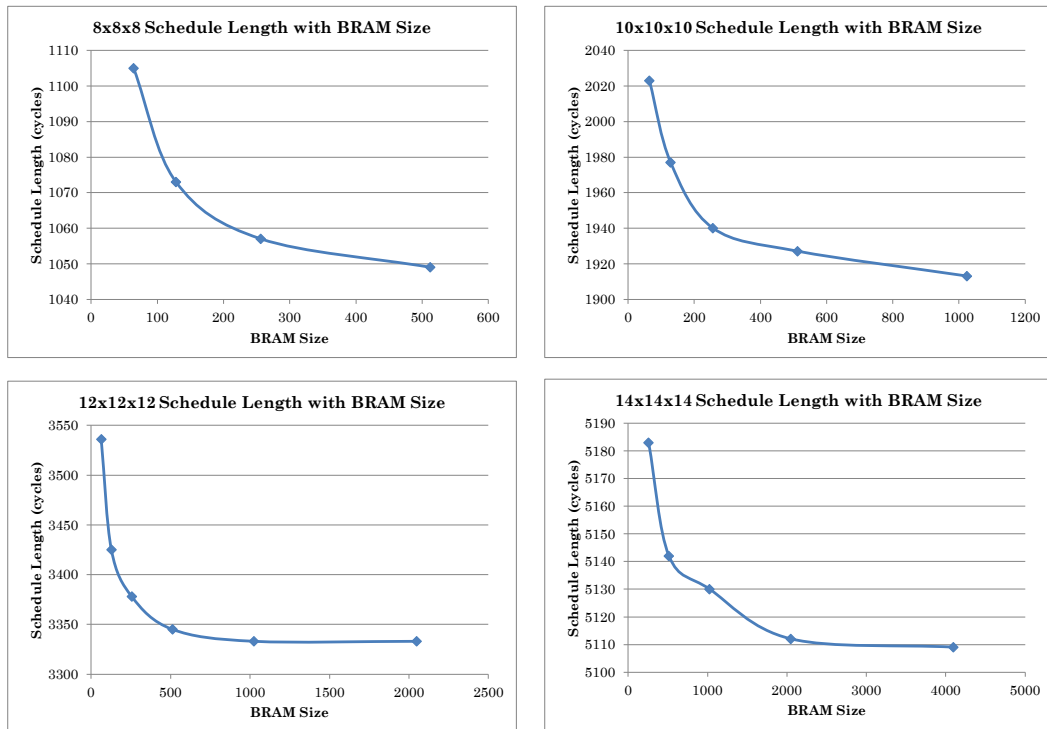

Figure 8.9: Matrix multiply total schedule length versus BRAM size constraint for 2-accelerator architecture.

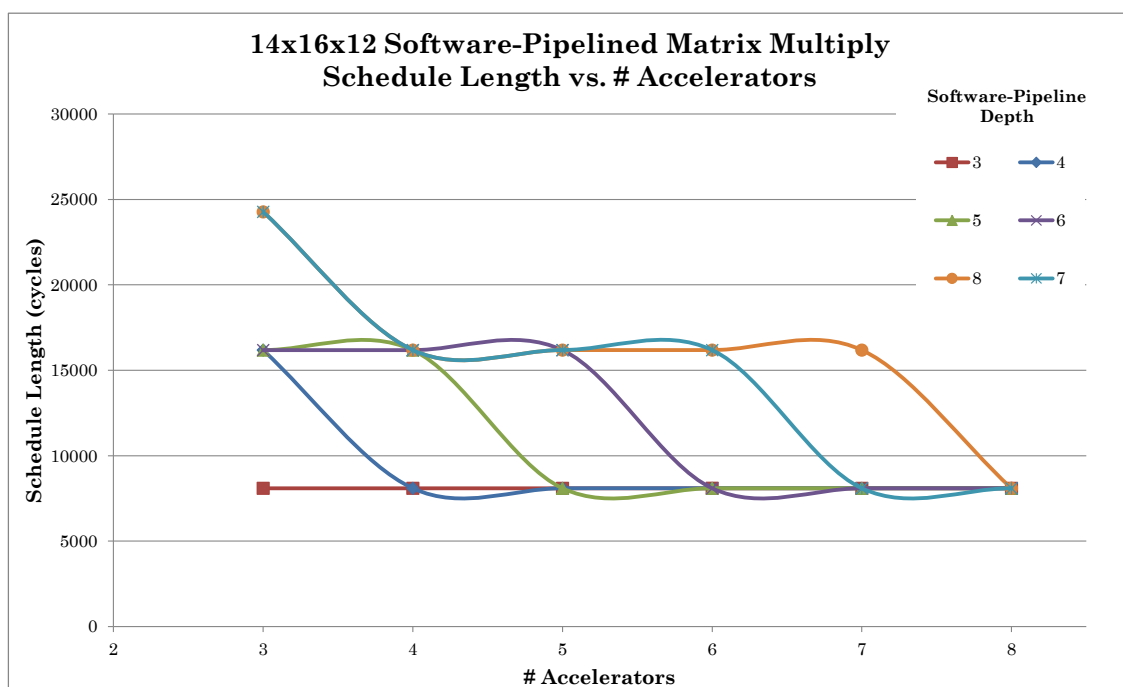

Figure 8.10: Matrix multiplication (of a 14x16 matrix with a 16x12 matrix) performance versus software pipeline depth & number of accelerators. It is interesting to note the trade-off between performance and device area. The jump for high-depth software pipelined designs shows a Pareto point that trades throughput for area.

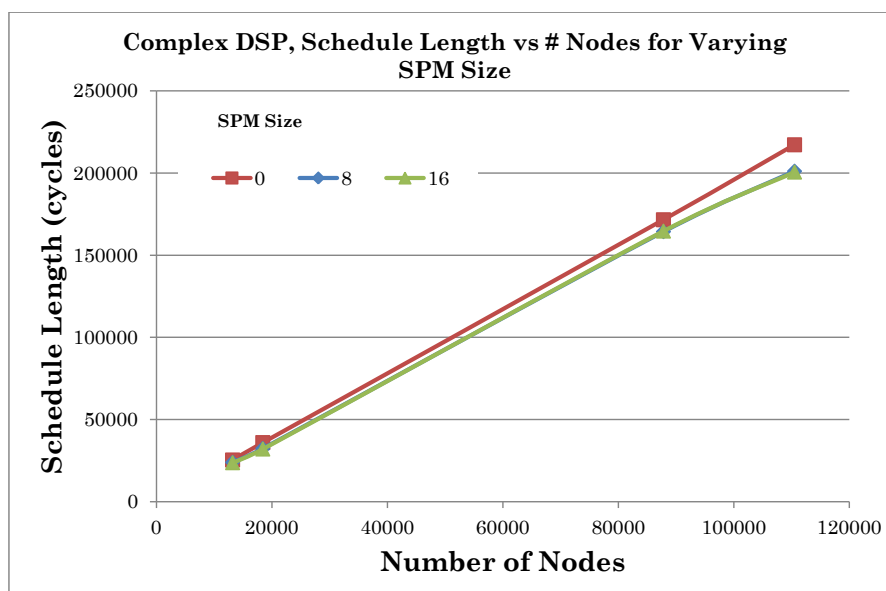

Figure 8.11: Scaling for complex DSP application illustrates the heuristics ability to preserve near-linear scalability for a variety of design shapes.

and 8, the gap between 3 and 4 accelerators is significant. This configuration may prove to be a better area/performance trade-off.

#### 8.4.2.1 Complex DSP Algorithm

The final demonstration chains image convolution with matrix multiply and FFT, shown in fig. 8.12. All three algorithms form a single graph. Fig. 8.11 shows a comparison of schedule length versus problem size for different scratchpad sizes. Interestingly, as the problem size scales up, the schedule length scales linearly, reflecting the tightly knit nature of the input data-flow graph.



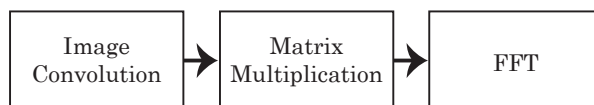

Figure 8.12: Algorithms chained together to form a complex DSP demonstration.

### 8.4.3 Utility and BRAM vs SPM Effectiveness

The primary performance differentiator is the scratchpad memory size. To evaluate why it eclipses BRAM size, fig. 8.13 demonstrates, for each application, the ratio of the cycles in which the DSP was occupied versus unoccupied/idle (the *utility*). For varying size of BRAM, there is little difference in utility. However, when the scratchpad memory is introduced, the additional memory ports allow better utility of computational cycles, and therefore yield faster schedules.

Fig. 8.14 shows the scratchpad utility over time (fig. 8.14a) and correspondingly the arithmetic utility over time (fig. 8.14b) for selected clusters of an FFT schedule. The values are cumulative – where it increases, it has made use of the resource. When it flattens out, it is waiting for the pipeline to clear or for memory ports to free. The majority of clusters exhibit this shape, as the algorithms are relatively dense and always have available operation.

## 8.5 Scaling to Very Large Problems

The final demonstration chains increasingly larger FFTs to matrix multiplication outputs. These were then chained together in long, concurrent pipes, forming a single graph into the millions of nodes. Fig. 8.15 shows the heuristic using a 2-deep software pipeline, 2 accelerators, and a BRAM size of 2048. Scaling is effec-

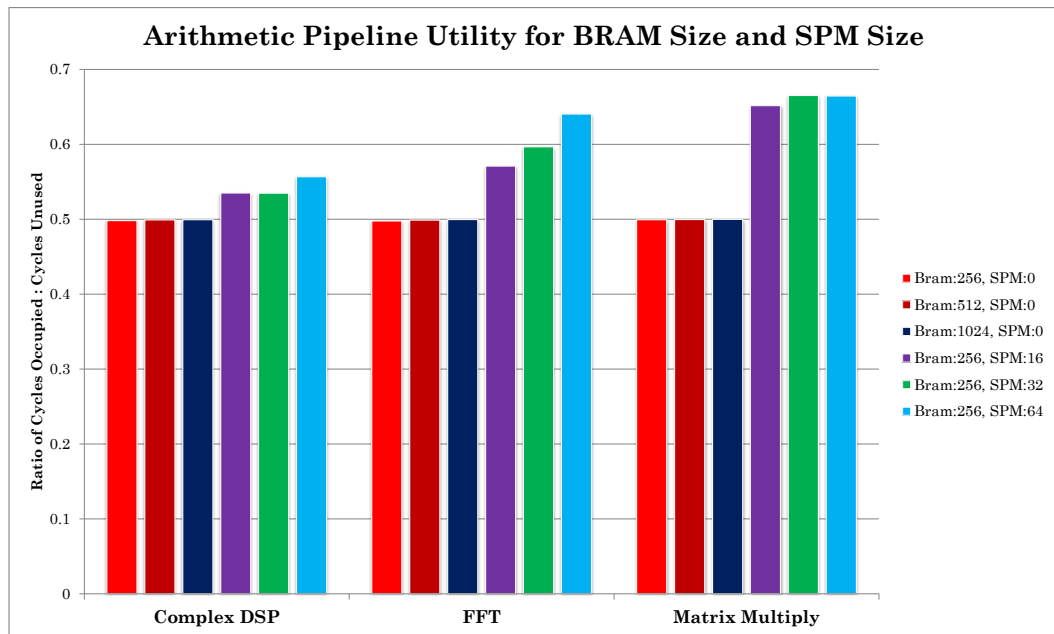
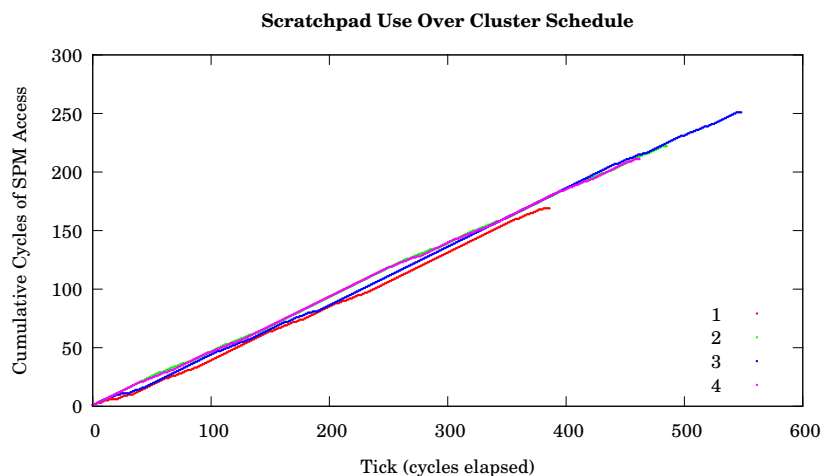
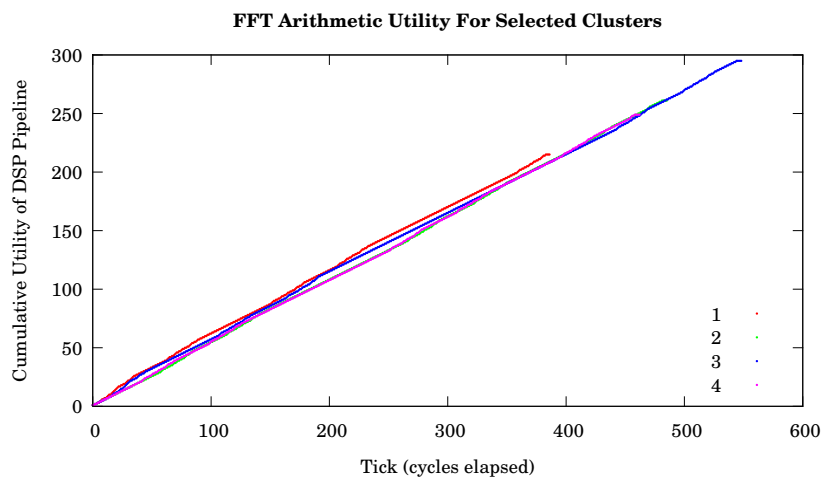

Figure 8.13: For each application, the utility represents the ratio of the used versus idle cycles in the arithmetic pipeline. As the BRAM size is varied, the utility remains relatively constant. Introducing a small scratchpad immediately increases utility; scratchpad size has a much greater impact on performance than BRAM size does.



(a) SPM utility over time



(b) Arithmetic utility over time

Figure 8.14: Visualization of scratchpad memory (SPM) and arithmetic pipeline utility for the same selected clusters of an FFT1024. The two are highly correlated: SPM size correlates strongly with higher performance, since fast access to operands allows the pipeline to remain busy.

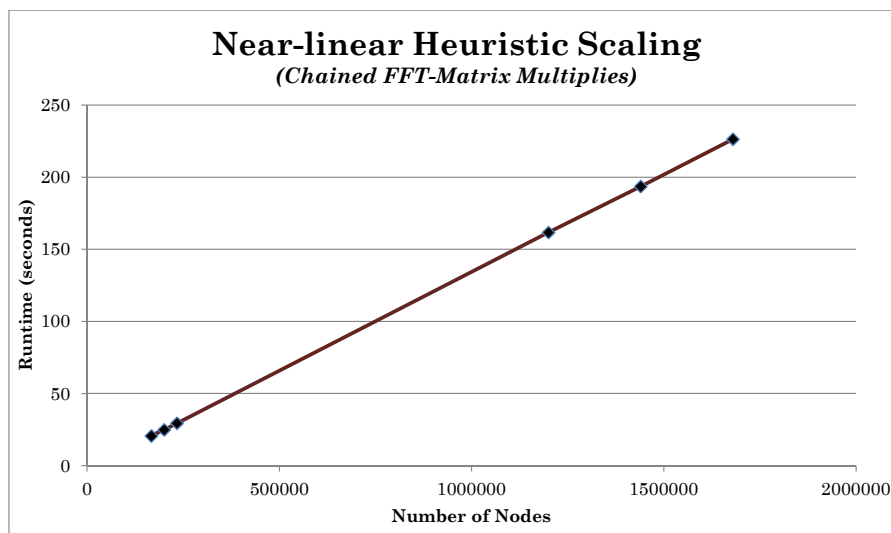

Figure 8.15: Heuristic runtime up to millions of nodes

tively linear, allowing this methodology to reach unprecedented design scales. A ~1.7 million node graph was clustered and scheduled with full memory constraints under 5 minutes.

## 8.6 Designer Insight

Automation exposes real system costs early in the design process through rapid design evaluation. The selected accelerator architecture suffered from memory port bottlenecks, illustrated by performance invariance to BRAM size. An alternative strategy using a scratchpad memory (even a relatively small one) is a significantly more effective use of available hardware resources. Instead of devoting more area to the BRAM, it can be routed towards much smaller scratchpad memory. Automation at these scales clearly grants designers insight into the problems they solve, and can handle capacity constraints and enormous problem sizes.

# Chapter 9

## Conclusions

Heterogeneous cosynthesis is a growing field, and this research has opened new potential to fluidly explore the architectural optimization space. Increased system heterogeneity brings with it unprecedented performance potential; the presented robust methodology provides a way to adapt to changing platforms without compromising performance. The hierarchical transactional framework lays groundwork for allowing rich specification of cosynthesis-targeted applications, leveraging a high degree of abstraction that keeps design expression concise. Its unique approach balances solutions for managing complex concurrent, latency tolerant tasks, with the ability to realize high performance implementations. This dissertation has demonstrated analysis of a control-dominated application, and full realization of a data-dominated high-performance signal processing suite.

Algorithms for mapping onto different semantic models underscore its ability to unify differing semantics in heterogeneous systems. A full suite of compiler tools enable practical design. At the same time, the semantics guide the designer towards specifications that do not hinder synthesis tools. Otherwise cumbersome

verification is made tenable through automated race condition identification, ameliorating common hurdles in ensuring concurrent tasks execute correctly.

Intrinsic flexibility brought about by state & control mobility creates opportunities to evaluate design configurations which were previously difficult to achieve automatically. By looking at the problem from an automation point of view, and structuring its semantics from the ground up, this research was able to identify and distill the core components required to allow truly automated cosynthesis.

## **9.1 Hierarchical Transaction Solutions**

The hierarchical transactional semantic model is built on a set of core philosophies that bring state management to the forefront, encapsulating data with its associated control in a way that opens a vast array of opportunities in language design, verification, and synthesis. This novel, ground-up semantic model was exercised with a rich set of tools to specify, compile, analyze, simulate, and synthesize designs. It meets the four cosynthesis goals laid out at the start.

The Hierarchical Transactional Language (HTL) supports clear, concise application specification that communicates designer intent. A rich expression syntax keeps the code readable yet compact, removing cumbersome implementation of low level architectural details. Careful language design allows a compiler to leverage an intelligent type inference system for powerful compile-time parameterization. It efficiently captures semantics underpinning its data and execution models, reflecting the model's unique properties while retaining syntactic familiarity to ex-

isting languages. Specifications of both a processor and FFT are understandable, reinforcing the value of a novel language-based approach.

Practical applicability of a language depends on the usefulness of its associated tools. The compiler directly addresses correctness via behavioral simulation and fast analysis tools. Through conventional means, race conditions are difficult to identify, with a tapestry of solutions stemming from decades of research. The presented race condition detection mechanism rapidly isolates concurrency bugs in the face of latency tolerant behavior. By leveraging the unique encapsulation properties of hierarchical transactions, this otherwise complex and untenable problem is reduced to an elegant, pseudo-linear solution. Additionally, the issue of closure opens the opportunity for automated closure logic synthesis: tools can intelligently avoid synchronization mechanisms that may affect performance. They no longer need to synthesize against worst-case behavior. Through a single graph traversal, the compiler learns every possible closure condition.

Heterogeneous applications span the gamut from control- to data-dominated designs. Processor and signal processing algorithm implementations bookend this spectrum to exercise the benefits of the semantic model. A full ISA-compatible implementation of an Texas Instruments MSP430 proves that rich control semantics are both expressible and executable. The race condition tool quickly discovered an unexpected concurrent write ordering situation that was resolved in minutes. In a more qualitative sense, specification of the processor was straightforward – the flow of control is generally understandable, in large part due to code compactness and a single control semantic (tokens).

At the computational end of application styles, the language and model were capable of concisely specifying and synthesizing high-arithmetic applications commonly found in signal processing. Iterators lay the scaffolding for well-behaved data-flow graphs by codifying repetitive behavior. The compact, concise FFT specification proves that composing iterators sufficiently expresses complex indexing.

A data-flow graph-based solution automatically realizes efficient high-performance designs. Iterators are cast into well-defined data-flow graphs. They are then scheduled to reach unprecedented scales (scaling to millions of nodes). The methodology exposes system costs early in the design process, allowing focused improvements on resource constraints contributing most to performance bottlenecks.

## **9.2 Open Problems**

Cosynthesis is an enormous problem space, and while hierarchical transactions have laid a solid foundation, there are outstanding opportunities to exercise the myriad aspects of this methodology. The largest area for research is in efficient control synthesis – arguably one of the most difficult elements to correct heterogeneous system design lies in orchestrating multiple components. Since the hierarchical transactional model codifies and encapsulates all state, there is potential to apply architectural synthesis in the form of automatic cache construction and distributed component synchronization.

Discussion of software scheduling has largely been omitted due to focus on optimization techniques and hardware targets. In the simplest implementation,



scheduling software transactions is similar to existing task scheduling solutions. When dealing with multiple software threads or processors, however, transactional encapsulation is invaluable in managing shared memory. The traditional locking/synchronization mechanisms (e.g. mutex and semaphore-based solutions) can be created only where necessary.

# Bibliography

- [1] K. Agrawal, J.T. Fineman, and J. Sukha. Nested parallelism in transactional memory. In *Proceedings of the 13th ACM SIGPLAN Symposium on Principles and practice of parallel programming*, pages 163–174. ACM, 2008.
- [2] K. Agrawal, C. E. Leiserson, and J. Sukha. Memory models for open-nested transactions. In *Proceedings of the 2006 workshop on Memory system performance and correctness*, MSPC '06, pages 70–81, New York, NY, USA, 2006. ACM.
- [3] A. Aleti, B. Buhnova, L. Grunske, A. Koziolk, and I. Meedeniya. Software Architecture Optimization Methods: A Systematic Literature Review. *Software Engineering, IEEE Transactions on*, 39(5):658–683, May 2013.
- [4] A. Allahverdi, C.T. Ng, T.C.E. Cheng, and M. Y. Kovalyov. A survey of scheduling problems with setup times or costs. *European Journal of Operational Research*, 187(3):985 – 1032, 2008.
- [5] K. R. Apt, N. Francez, and W. P. De Roever. A proof system for communicating sequential processes. *ACM Transactions on Programming Languages and Systems (TOPLAS)*, 2(3):359–385, 1980.

- [6] P. Arato, S. Juhasz, Z.A Mann, A Orban, and D. Papp. Hardware-software partitioning in embedded system design. In *Intelligent Signal Processing, 2003 IEEE International Symposium on*, pages 197–202, Sept 2003.
- [7] K. Asanovic. Transactors for parallel hardware and software co-design. In *High Level Design Validation and Test Workshop, 2007. HLVDT 2007. IEEE International*, pages 140 –142, nov. 2007.
- [8] J. Axelsson. Architecture synthesis and partitioning of real-time systems: A comparison of three heuristic search strategies. In *Hardware/Software Codesign, 1997.(CODES/CASHE'97), Proceedings of the Fifth International Workshop on*, pages 161–165. IEEE, 1997.
- [9] F. Balarin and R. Passerone. Specification, Synthesis, and Simulation of Transactor Processes. *Computer-Aided Design of Integrated Circuits and Systems, IEEE Transactions on*, 26(10):1749 –1762, oct. 2007.
- [10] F. Balarin, Y. Watanabe, H. Hsieh, et al. Metropolis: An integrated electronic system design environment. *Computer*, 36(4):45–52, 2003.
- [11] G. Bracha and S. Toueg. Distributed deadlock detection. *Distributed Computing*, 2(3):127–138, 1987.
- [12] L. Cai and D. Gajski. Transaction level modeling: an overview. In *Proceedings of the 1st IEEE/ACM/IFIP international conference on Hardware/software codesign and system synthesis*, CODES+ISSS '03, pages 19–24, New York, NY, USA, 2003. ACM.

- [13] L.P. Carloni, K.L. McMillan, and A.L. Sangiovanni-Vincentelli. Theory of latency-insensitive design. *IEEE Transactions on Computer-Aided Design of Integrated Circuits and Systems*, 20(9):1059–1076, 2001.
- [14] J. Castrillon, W. Sheng, and R. Leupers. Trends in embedded software synthesis. In *Embedded Computer Systems (SAMOS), 2011 International Conference on*, pages 347–354. IEEE, 2011.
- [15] K. S. Chatha and R. Vemuri. MAGELLAN: multiway hardware-software partitioning and scheduling for latency minimization of hierarchical control-dataflow task graphs. In *Proceedings of the ninth international symposium on Hardware/software codesign, CODES '01*, pages 42–47, New York, NY, USA, 2001. ACM.
- [16] S. Cheng, J. A. Stankovic, and K. Ramamritham. Scheduling Algorithms for Hard Real-Time Systems—A Brief Survey. Technical report, Amherst, MA, USA, 1987.
- [17] P.H. Chou, R.B. Ortega, and G. Borriello. The Chinook hardware/software co-synthesis system. In *Proceedings of the 8th international symposium on System synthesis*, pages 22–27. ACM, 1995.
- [18] E.G. Coffman, M. Elphick, and A. Shoshani. System deadlocks. *ACM Computing Surveys (CSUR)*, 3(2):78, 1971.
- [19] J. Cong, B. Liu, S. Neuendorffer, et al. High-level synthesis for FPGAs: From prototyping to deployment. *Computer-Aided Design of Integrated Circuits and Systems, IEEE Transactions on*, 30(4):473–491, 2011.

- [20] J.W. Cooley and J.W. Tukey. An algorithm for the machine calculation of complex Fourier series. *Mathematics of computation*, 19(90):297–301, 1965.
- [21] J. Cortadella, M. Kishinevsky, and B. Grundmann. SELF: Specification and design of synchronous elastic circuits. In *TAU'06: Proceedings of the ACM/IEEE International Workshop on Timing Issues 2006*. Citeseer, 2006.
- [22] J. Cortadella, M. Kishinevsky, and B. Grundmann. Synthesis of synchronous elastic architectures. In *DAC '06: Proceedings of the 43rd annual Design Automation Conference*, pages 657–662, New York, NY, USA, 2006. ACM.
- [23] L.A. Cortés, P. Eles, and Z. Peng. A Survey on Hardware/Software Code-design Representation Models. Technical report, Department of Computer and Information Science Linköping University, S-581 83 Linköping, Sweden, June 1999.
- [24] W.J. Dally and C.L. Seitz. Deadlock-free message routing in multiprocessor interconnection networks. *IEEE Transactions on computers*, 36(5):547–553, 1987.
- [25] B. P. Dave, G. Lakshminarayana, and N. K. Jha. COSYN: hardware-software co-synthesis of embedded systems. In *Proceedings of the 34th annual Design Automation Conference, DAC '97*, pages 703–708, New York, NY, USA, 1997. ACM.
- [26] B.P. Dave and N.K. Jha. COHRA: hardware-software cosynthesis of hierarchical heterogeneous distributed embedded systems. *Computer-Aided Design*

- of Integrated Circuits and Systems, IEEE Transactions on*, 17(10):900–919, oct 1998.
- [27] G. De Micheli. Hardware synthesis from C/C++ models. In *Proceedings of the conference on Design, automation and test in Europe*, page 80. ACM, 1999.
- [28] R.P. Dick and N.K. Jha. CORDS: hardware-software co-synthesis of reconfigurable real-time distributed embedded systems. In *Proceedings of the 1998 IEEE/ACM international conference on Computer-aided design*, pages 62–67. ACM, 1998.
- [29] S.A. Edwards. The challenges of hardware synthesis from C-like languages. In *Design, Automation and Test in Europe, 2005. Proceedings*, pages 66–67. IEEE, 2005.
- [30] P. Eles, Z. Peng, K. Kuchcinski, and A. Daboli. System Level Hardware/Software Partitioning Based on Simulated Annealing and Tabu Search. *Design Automation for Embedded Systems*, 2(1):5–32, 1997.
- [31] D. D. Gajski, J. Zhu, R. Domer, A. Gerstlauer, and S. Zhao. SPECC: Specification Language and Methodology. 2000.
- [32] W.M. Gentleman and G. Sande. Fast Fourier Transforms: for fun and profit. In *Proceedings of the November 7-10, 1966, fall joint computer conference*, pages 563–578. ACM, 1966.

- [33] A. Gerstlauer, C. Haubelt, A.D. Pimentel, et al. Electronic System-Level Synthesis Methodologies. *Computer-Aided Design of Integrated Circuits and Systems, IEEE Transactions on*, 28(10):1517–1530, Oct. 2009.
- [34] R.K. Gupta, Jr. Claudionor, N.C., and G. De Micheli. Program implementation schemes for hardware-software systems. *Computer*, 27(1):48–55, Jan 1994.
- [35] R.K. Gupta and G. De Micheli. *Co-synthesis of hardware and software for digital embedded systems*, volume 4. Kluwer academic publishers Boston, MA, 1995.
- [36] S. Ha, S. Kim, C. Lee, et al. PeaCE: A hardware-software codesign environment for multimedia embedded systems. *ACM Transactions on Design Automation of Electronic Systems (TODAES)*, 12(3):24, 2007.
- [37] L. Hammond, V. Wong, M. Chen, et al. Transactional memory coherence and consistency. In *ACM SIGARCH Computer Architecture News*, volume 32, page 102. IEEE Computer Society, 2004.
- [38] C. Haubelt, J. Falk, J. Keinert, et al. A SystemC-based design methodology for digital signal processing systems. *EURASIP J. Embedded Syst.*, 2007(1):15–15, January 2007.
- [39] C. Haubelt, J. Teich, K. Richter, and R. Ernst. System design for flexibility. In *Proceedings of the conference on Design, automation and test in Europe*, page 854. IEEE Computer Society, 2002.

- [40] J. Henkel. A Low Power Hardware/Software Partitioning Approach for Core-based Embedded Systems. In *Proceedings of the 36th Annual ACM/IEEE Design Automation Conference, DAC '99*, pages 122–127, New York, NY, USA, 1999. ACM.
- [41] J. Henkel and R. Ernst. An approach to automated hardware/software partitioning using a flexible granularity that is driven by high-level estimation techniques. *Very Large Scale Integration (VLSI) Systems, IEEE Transactions on*, 9(2):273–289, April 2001.
- [42] J. Henkel, R. Ernst, U. Holtmann, and T. Benner. Adaptation of partitioning and high-level synthesis in hardware/software co-synthesis. In *Proceedings of the 1994 IEEE/ACM international conference on Computer-aided design*, pages 96–100. IEEE Computer Society Press, 1994.
- [43] M. Herlihy and J.E.B. Moss. Transactional memory: Architectural support for lock-free data structures. *ACM SIGARCH Computer Architecture News*, 21(2):289–300, 1993.
- [44] W. Herroelen, B. De Reyck, and E. Demeulemeester. Resource-constrained project scheduling: A survey of recent developments. *Computers & Operations Research*, 25(4):279 – 302, 1998.
- [45] J.I Hidalgo and J. Lanchares. Functional partitioning for hardware-software codesign using genetic algorithms. In *EUROMICRO 97. New Frontiers of Information Technology., Proceedings of the 23rd EUROMICRO Conference*, pages 631–638, Sept 1997.



- [46] C.A.R. Hoare. Communicating sequential processes. *Communications of the ACM*, 21(8):666–677, 1978.
- [47] B. Holland, M. Vacas, V. Aggarwal, et al. Survey of C-based application mapping tools for reconfigurable computing. In *Proceedings of the 8th International Conference on Military and Aerospace Programmable Logic Devices (MAPLD'05)*, 2005.
- [48] G. Hoover. *Distributed Control For Embedded System Design*. PhD thesis, University of California, Santa Barbara, Santa Barbara, California, 2008.
- [49] G. Hoover and F. Brewer. Synthesizing synchronous elastic flow networks. In *DATE '08: Proceedings of the conference on Design, automation and test in Europe*, pages 306–311, New York, NY, USA, 2008. ACM.
- [50] T. Horder and K. Rothermel. Concurrency control issues in nested transactions. *The VLDB Journal—The International Journal on Very Large Data Bases*, 2(1):39–74, 1993.
- [51] A. Jantsch, P. Ellervee, A. Hemani, J. Öberg, and H. Tenhunen. Hardware/Software Partitioning and Minimizing Memory Interface Traffic. In *Proceedings of the Conference on European Design Automation, EURO-DAC '94*, pages 226–231, Los Alamitos, CA, USA, 1994. IEEE Computer Society Press.
- [52] A. Kalavade and E. A. Lee. A Global Criticality/Local Phase Driven Algorithm for the Constrained Hardware/Software Partitioning Problem. In *Proceedings of the 3rd International Workshop on Hardware/Software Co-design*,

- CODES '94, pages 42–48, Los Alamitos, CA, USA, 1994. IEEE Computer Society Press.
- [53] J. Keinert, M. Streubühorbar, T. Schlichter, et al. SystemCoDesigner—an automatic ESL synthesis approach by design space exploration and behavioral synthesis for streaming applications. *ACM Transactions on Design Automation of Electronic Systems (TODAES)*, 14(1):1:1–1:23, January 2009.
- [54] B.W. Kernighan and S. Lin. An efficient heuristic procedure for partitioning graphs. *Bell system technical journal*, 49(2):291–307, 1970.
- [55] V. Kianzad and S.S. Bhattacharyya. CHARMED: a multi-objective co-synthesis framework for multi-mode embedded systems. In *Application-Specific Systems, Architectures and Processors, 2004. Proceedings. 15th IEEE International Conference on*, pages 28–40, Sept 2004.
- [56] D. Kim and S. Ha. Static analysis and automatic code synthesis of flexible FSM model. In *Proceedings of the 2005 Asia and South Pacific Design Automation Conference*, pages 161–165. ACM, 2005.
- [57] M. Kim, S. Banerjee, N. Dutt, and N. Venkatasubramanian. Energy-aware cosynthesis of real-time multimedia applications on MPSoCs using heterogeneous scheduling policies. *ACM Trans. Embed. Comput. Syst.*, 7:9:1–9:19, January 2008.
- [58] M. King, N. Dave, et al. Automatic generation of hardware/software interfaces. In *ACM SIGARCH Computer Architecture News*, volume 40, pages 325–336. ACM, 2012.

- [59] S. Klaus, S. Huss, and T. Trautmann. Automatic Generation of Scheduled SystemC Models of Embedded Systems from Extended Task Graphs. In Eugenio Villar and Jean Mermet, editors, *System Specification and Design Languages*, pages 207–217. Springer US, 2003.
- [60] P.V. Knudsen and J. Madsen. PACE: A Dynamic Programming Algorithm for Hardware/Software Partitioning. In *Proceedings of the 4th International Workshop on Hardware/Software Co-Design, CODES '96*, pages 85–, Washington, DC, USA, 1996. IEEE Computer Society.
- [61] N. Krivokapić, A. Kemper, and E. Gudes. Deadlock detection in distributed database systems: a new algorithm and a comparative performance analysis. *The VLDB journal*, 8(2):79–100, 1999.
- [62] M. Kudlugi, S. Hassoun, C. Selvidge, and D. Pryor. A transaction-based unified simulation/emulation architecture for functional verification. In *Design Automation Conference, 2001. Proceedings*, pages 623 – 628, 2001.
- [63] E.A. Lee and II John. Overview of the ptolemy project, 1999.
- [64] M. López-Vallejo and J. C. López. On the Hardware-software Partitioning Problem: System Modeling and Partitioning Techniques. *ACM Trans. Des. Autom. Electron. Syst.*, 8(3):269–297, July 2003.
- [65] M. Lukasiewicz, M. Streubuhr, M. Glass, C. Haubelt, and J. Teich. Combined system synthesis and communication architecture exploration for MP-SoCs. In *Design, Automation Test in Europe Conference Exhibition, 2009. DATE '09.*, pages 472–477, april 2009.

- [66] R. Lysecky and F. Vahid. A study of the speedups and competitiveness of FPGA soft processor cores using dynamic hardware/software partitioning. In *Design, Automation and Test in Europe, 2005. Proceedings*, pages 18–23 Vol. 1, March 2005.
- [67] B. Meals. Hierarchical Decomposition Algorithm for Hardware/Software Partitioning. In *Proceedings of the 44th Annual Southeast Regional Conference*, ACM-SE 44, pages 18–23, New York, NY, USA, 2006. ACM.
- [68] R. Niemann and P. Marwedel. An Algorithm for Hardware/Software Partitioning Using Mixed Integer Linear Programming. *Design Automation for Embedded Systems*, 2(2):165–193, 1997.
- [69] H. Nikolov, M. Thompson, T. Stefanov, et al. Daedalus: Toward Composable Multimedia MP-SoC Design. In *Proceedings of the 45th Annual Design Automation Conference*, DAC '08, pages 574–579, New York, NY, USA, 2008. ACM.
- [70] H. Oh and S. Ha. Hardware-software cosynthesis of multi-mode multi-task embedded systems with real-time constraints. In *Proceedings of the tenth international symposium on Hardware/software codesign*, pages 133–138. ACM, 2002.
- [71] C.S. Pășăreanu and W. Visser. A survey of new trends in symbolic execution for software testing and analysis. *International journal on software tools for technology transfer*, 11(4):339–353, 2009.

- [72] S. Pasricha, N. Dutt, E. Bozorgzadeh, and M. Ben-Romdhane. Floorplan-aware automated synthesis of bus-based communication architectures. In *Proceedings of the 42nd annual Design Automation Conference, DAC '05*, pages 565–570, New York, NY, USA, 2005. ACM.
- [73] H.D. Patel, S.K. Shukla, E. Mednick, and R.S. Nikhil. A rule-based model of computation for SystemC: integrating SystemC and Bluespec for co-design. In *Formal Methods and Models for Co-Design, 2006. MEMOCODE '06. Proceedings. Fourth ACM and IEEE International Conference on*, pages 39–48, july 2006.
- [74] I. Puaut and C. Pais. Scratchpad memories vs locked caches in hard real-time systems: a quantitative comparison. In *Design, Automation & Test in Europe Conference & Exhibition, 2007. DATE'07*, pages 1–6. IEEE, 2007.
- [75] G. Quan, X.S. Hu, and G. Greenwood. Preference-driven hierarchical hardware/software partitioning. In *Computer Design, 1999. (ICCD '99) International Conference on*, pages 652–657, 1999.
- [76] D. Saha, R.S. Mitra, and A Basu. Hardware software partitioning using genetic algorithm. In *VLSI Design, 1997. Proceedings., Tenth International Conference on*, pages 155–160, Jan 1997.
- [77] A. Sangiovanni-Vincentelli. Quo vadis, SLD? reasoning about the trends and challenges of system level design. *Proceedings of the IEEE*, 95(3):467–506, 2007.

- [78] L. Séméria and G. De Micheli. SpC: synthesis of pointers in C application of pointer analysis to the behavioral synthesis from C. In *Computer-Aided Design, 1998. ICCAD 98. Digest of Technical Papers. 1998 IEEE/ACM International Conference on*, pages 340–346. IEEE, 1998.
- [79] M. B. Srivastava and R. W Brodersen. Rapid-prototyping of hardware and software in a unified framework. In *Computer-Aided Design, 1991. ICCAD-91. Digest of Technical Papers., 1991 IEEE International Conference on*, pages 152–155. IEEE, 1991.
- [80] J. Teich. Hardware/Software Codesign: The Past, the Present, and Predicting the Future. *Proceedings of the IEEE*, 100(Special Centennial Issue):1411–1430, May 2012.
- [81] Texas Instruments. *MSP430i2xx Family User’s Guide*, August 2014.
- [82] M. Thompson, H. Nikolov, T. Stefanov, et al. A Framework for Rapid System-level Exploration, Synthesis, and Programming of Multimedia MP-SoCs. In *Proceedings of the 5th IEEE/ACM International Conference on Hardware/Software Codesign and System Synthesis, CODES+ISSS ’07*, pages 9–14, New York, NY, USA, 2007. ACM.
- [83] F. Vahid, D. D. Gajski, and J. Gong. A Binary-constraint Search Algorithm for Minimizing Hardware During Hardware/Software Partitioning. In *Proceedings of the Conference on European Design Automation, EURO-DAC ’94*, pages 214–219, Los Alamitos, CA, USA, 1994. IEEE Computer Society Press.

- [84] T. Wiangtong, P.Y.K. Cheung, and W. Luk. Comparing Three Heuristic Search Methods for Functional Partitioning in Hardware/Software Codesign. *Design Automation for Embedded Systems*, 6(4):425–449, 2002.
- [85] F. Winterstein, S. Bayliss, and G.A Constantinides. High-level synthesis of dynamic data structures: A case study using Vivado HLS. In *Field-Programmable Technology (FPT), 2013 International Conference on*, pages 362–365, Dec 2013.
- [86] W. Wolf. A decade of hardware/software codesign. *Computer*, 36(4):38 – 43, april 2003.
- [87] W. Wolf. Design Challenges in Multiprocessor Systems-on-Chip. In Bernd Kleinjohann, Lisa Kleinjohann, Ricardo Machado, Carlos Pereira, and P. Thiagarajan, editors, *From Model-Driven Design to Resource Management for Distributed Embedded Systems*, volume 225 of *IFIP International Federation for Information Processing*, pages 1–8. Springer Boston, 2006.
- [88] W. Wolf, AA Jerraya, and G. Martin. Multiprocessor System-on-Chip (MP-SoC) Technology. *Computer-Aided Design of Integrated Circuits and Systems, IEEE Transactions on*, 27(10):1701–1713, Oct 2008.
- [89] N.S. Woo, A.E. Dunlop, and W. Wolf. Codesign from cospecification. *Computer*, 27(1):42 –47, jan 1994.
- [90] Xilinx. *Vivado Design Suite User Guide: Designing With IP*, October 2013.

## *Bibliography*

---

- [91] Y. Zhang, X. S. Hu, and D. Z. Chen. Task scheduling and voltage selection for energy minimization. In *Proceedings of the 39th annual Design Automation Conference*, DAC '02, pages 183–188, New York, NY, USA, 2002. ACM.



# Appendix A

## HTL Grammar

$\langle spec \rangle ::= \langle stmt \rangle^*$

$\langle rule-def \rangle ::= \text{'rule' } \langle ident \rangle \langle token-guard-list \rangle \langle rule-input \rangle? \text{' : ' suite}$

$\langle rule-input \rangle ::= \langle rule-input-list \rangle$

|

$\langle rule-input-list \rangle ::= \text{'<- ' ( ' ( } \langle ident \rangle \text{' , ' ) * ' '}$

|

$\langle token-guard-list \rangle ::= \langle empty \rangle$

|  $\text{'( ' } \langle token-guard \rangle \text{' )'}$

$\langle token-guard \rangle ::= \langle token-guard-or \rangle$

$\langle token-guard-or \rangle ::= \langle token-guard-and \rangle \text{'or' } \langle token-guard-and \rangle^*$

$\langle token-guard-and \rangle ::= \langle token-atom \rangle \text{'and' } \langle token-atom \rangle^*$

$\langle token-atom \rangle ::= \langle ident \rangle$

|  $\text{'( ' } \langle token-guard-or \rangle \text{' )'}$

$\langle stmt \rangle ::= \langle simple-stmt \rangle$

|  $\langle compound-stmt \rangle$

$\langle simple-stmt \rangle ::= \langle small-stmt \rangle ( ';' \langle small-stmt \rangle )^* \langle newline \rangle$

$\langle small-stmt \rangle ::= \langle vardecl-stmt \rangle$

|  $\langle assign-stmt \rangle$

|  $\langle print-stmt \rangle$

|  $\langle create-stmt \rangle$

|  $\langle pass-stmt \rangle$

|  $\langle return-stmt \rangle$

|  $\langle import-stmt \rangle$

|  $\langle modifier-stmt \rangle$

$\langle compound-stmt \rangle ::= \langle if-stmt \rangle$

|  $\langle for-stmt \rangle$

|  $\langle rule-def \rangle$

|  $\langle class-def \rangle$

|  $\langle call-stmt \rangle$

$\langle vardecl-stmt \rangle ::= \text{'var'} \langle ident \rangle ( ',' \langle ident \rangle )^* ':' \langle ident \rangle ( '(' \langle arglist \rangle? ')' )?$

$\langle assign-stmt \rangle ::= \langle lvalue-list \rangle \text{'='} \langle test-list \rangle$

$\langle aug-assign \rangle ::= \text{'+='} | \text{'-='} | \text{'*='} | \text{'/=}' | \text{'%='} | \text{'\&='} | \text{'|='} | \text{'^='} | \text{'<<='} | \text{'>>='}$

$\langle print-stmt \rangle ::= \text{'print'} \langle test-list \rangle$   $\langle create-stmt \rangle ::= \text{'create'} \langle ident \rangle \langle pass-stmt \rangle$

$::= \text{'pass'}$

$\langle \text{flow-stmt} \rangle ::= \langle \text{break-stmt} \rangle$

|  $\langle \text{continue-stmt} \rangle$

|  $\langle \text{return-stmt} \rangle$

$\langle \text{return-stmt} \rangle ::= \text{'return' } \langle \text{test-list} \rangle$   $\langle \text{continue-stmt} \rangle ::= \text{'continue' } \langle \text{break-stmt} \rangle$

$::= \text{'break'}$

$\langle \text{import-stmt} \rangle ::= \text{'import' } \langle \text{import-item} \rangle (\text{' ,' } \langle \text{import-item} \rangle)^* \langle \text{import-item} \rangle ::=$

$\langle \text{ident} \rangle (\text{'as' } \langle \text{ident} \rangle)?$

$\langle \text{modifier-stmt} \rangle ::= \text{'@' } \langle \text{ident} \rangle (\text{'(' } \langle \text{arglist} \rangle? \text{'})' )?$

$\langle \text{compoint-stmt} \rangle ::= \langle \text{if-stmt} \rangle$

|  $\langle \text{for-stmt} \rangle$

|  $\langle \text{rule-def} \rangle$

|  $\langle \text{class-def} \rangle$

|  $\langle \text{call-stmt} \rangle$

$\langle \text{if-stmt} \rangle ::= \text{'if' } \langle \text{test} \rangle \text{' :' } \langle \text{suite} \rangle \langle \text{elif-clause} \rangle^* (\text{'else' } \text{' :' } \langle \text{suite} \rangle)?$

$\langle \text{elif-clause} \rangle ::= \text{'elif' } \langle \text{test} \rangle \text{' :' } \langle \text{suite} \rangle$

$\langle \text{for-stmt} \rangle ::= \text{'for' } \langle \text{for-iterators} \rangle \text{' :' } \langle \text{suite} \rangle \langle \text{for-finally} \rangle?$

$\langle \text{for-finally} \rangle ::= \text{'finally' } \text{' :' } \langle \text{suite} \rangle$

$\langle \text{for-iterators} \rangle ::= \langle \text{iterator-spec} \rangle (\text{'||' } \langle \text{iterator-spec} \rangle)^*$

$\langle \text{iterator-spec} \rangle ::= \langle \text{lvalue-list} \rangle \text{'in' } \langle \text{test-list} \rangle$

$\langle \text{call-stmt} \rangle ::= \text{'call' } (\langle \text{lvalue-list} \rangle \text{'='})? \langle \text{test-list} \rangle \langle \text{call-optional-suite} \rangle$

$\langle \text{call-optional-suite} \rangle ::= \text{' :' } \langle \text{call-suite} \rangle$

| NEWLINE

$$\begin{aligned}
\langle \text{creates-token-rename} \rangle &::= \langle \text{ident} \rangle ( \text{'->'} \langle \text{ident} \rangle ) \\
\langle \text{creates-stmt} \rangle &::= \text{'creates'} \langle \text{creates-token-name} \rangle + \\
\langle \text{call-param-small-stmt} \rangle &::= \langle \text{creates-stmt} \rangle \\
&| \langle \text{pass-stmt} \rangle \\
\langle \text{call-param-stmt} \rangle &::= \langle \text{call-param-small-stmt} \rangle ( \text{';' } \langle \text{call-param-small-stmt} \rangle )^* \\
\langle \text{call-suite} \rangle &::= \langle \text{call-param-stmt} \rangle \\
&| \text{NEWLINE INDENT } \langle \text{call-param-stmt} \rangle + \text{DEDENT} \\
\langle \text{suite} \rangle &::= \langle \text{simple-stmt} \rangle \\
&| \text{NEWLINE INDENT } \langle \text{stmt} \rangle + \text{DEDENT} \\
\langle \text{test} \rangle &::= \langle \text{or-test} \rangle \\
\langle \text{or-test} \rangle &::= \langle \text{and-test} \rangle ( \text{'or'} \langle \text{and-test} \rangle )^* \\
\langle \text{and-test} \rangle &::= \langle \text{not-test} \rangle ( \text{'and'} \langle \text{not-test} \rangle )^* \\
\langle \text{not-test} \rangle &::= \text{'not'} \langle \text{not-test} \rangle \\
&| \langle \text{comparison} \rangle \\
\langle \text{comparison} \rangle &::= \langle \text{expr} \rangle ( \langle \text{comp-op} \rangle \langle \text{expr} \rangle )^* \\
\langle \text{comp-op} \rangle &::= \text{'<'} \\
&| \text{'>'} \\
&| \text{'==' } \\
&| \text{'>=' } \\
&| \text{'<=' } \\
&| \text{'=<'}
\end{aligned}$$

| '!='  
 | '~='  
  
 $\langle expr \rangle ::= \langle tuple\text{-}expr \rangle$   
 $\langle tuple\text{-}expr \rangle ::= \langle expr\text{-}t \rangle$   
 | '('  $\langle expr\text{-}t \rangle$  (','  $\langle expr\text{-}t \rangle$ )+' '  
 $\langle expr\text{-}t \rangle ::= \langle xor\text{-}expr \rangle$  ('|'  $\langle xor\text{-}expr \rangle$ )\*  
 $\langle xor\text{-}expr \rangle ::= \langle and\text{-}expr \rangle$  ('^'  $\langle and\text{-}expr \rangle$ )\*  
 $\langle and\text{-}expr \rangle ::= \langle shift\text{-}expr \rangle$  ('&'  $\langle shift\text{-}expr \rangle$ )\*  
 $\langle shift\text{-}expr \rangle ::= \langle arith\text{-}expr \rangle$  (('<<' | '>>')  $\langle arith\text{-}expr \rangle$ )\*  
 $\langle arith\text{-}expr \rangle ::= \langle term \rangle$  (('+' | '-' )  $\langle term \rangle$ )\*  
 $\langle term \rangle ::= \langle factor \rangle$  (('\*' | '/' | '%' | '//')  $\langle factor \rangle$ )\*  
 $\langle factor \rangle ::= '+' \langle factor \rangle$   
 | '-'  $\langle factor \rangle$   
 | '~'  $\langle factor \rangle$   
 |  $\langle trailer \rangle$   
 $\langle trailer \rangle ::= \langle atom \rangle$  ('['  $\langle subscript \rangle$  ']' | '.'  $\langle ident \rangle$  | '('  $\langle arg\text{-}list \rangle$  ')'  
 $\langle atom \rangle ::=$  '('  $\langle test \rangle$ ? ')'  
 |  $\langle ident \rangle$   
 |  $\langle int \rangle$   
 |  $\langle float \rangle$   
 |  $\langle string \rangle$ +  
 | 'true' | 'false'

$\langle subscript \rangle ::= \langle test \rangle ( \text{' : ' } \langle test \rangle )^*$

$\langle expr-list \rangle ::= ( \langle expr \rangle \text{' , ' } )^+$

$\langle test-list \rangle ::= ( \langle test \rangle \text{' , ' } )^+$

$\langle lvalue-list \rangle ::= \langle lvalue-item \rangle ( \text{' , ' } \langle lvalue-item \rangle )^*$

$\langle lvalue-item \rangle ::= \langle trailer \rangle$

$\langle class-def \rangle ::= \text{' class ' } \langle ident \rangle ( ( \text{' ( ' } \langle arg-list \rangle \text{' ) ' } )? \langle rule-input \rangle? \text{' : ' } \langle suite \rangle$

$\langle arg-list \rangle ::= ( \langle argument \rangle \text{' , ' } )^*$

$\langle argument \rangle ::= \langle ident \rangle \text{' = ' } \langle test \rangle$

|  $\langle test \rangle$

# Appendix B

## FFT and MSP430 Code Listing

### B.1 FFT HTL Code Listing

```
1 import math
2
3 class FFT<-(size, type):
4     rule fft<-(self, Input, Coefficients):
5         var stages: Int(math.log2(self.size))
6         var i_stages: IIntSequence(stages)
7         var intermediates: Array(self.size, self.type) #
            intermediate results
8         @unroll
9         @pipeline(Input, intermediates)
10        for stage in i_stages:
11
12            print "stage = ", stage
13
14            # Calculate the "skip" size for this stage
15            var cluster_size: Int(math.pow(2, stages-stage))
16            var rr_size: Int(math.pow(2, stages-stage-1),
                verbose='rr_size: ')
17
18            # Instantiate iterators
19            var in_clustered: IClustered(Input, cluster_size
                )
20            var coef_clustered: IClustered(Coefficients,
                cluster_size)
21            var out_clustered: IClustered(intermediates,
                cluster_size)
22
23            # Iterate over the sub cluster
24            for in_cluster in in_clustered || \
25                c_cluster in coef_clustered || \
```

```

26         out_cluster in out_clustered:
27
28         # Now iterate within the group
29         var i_in:   IGroupedRoundRobin(in_cluster,
30             rr_size, rr_size)
31         var i_coef: IGroupedRoundRobin(c_cluster,
32             rr_size, rr_size)
33         var i_out:  IGroupedRoundRobin(out_cluster,
34             rr_size, rr_size)
35         var tmp: Bits(16)
36         for out0, out1 in i_out || x, y in i_in || coef
37             , nul in i_coef:
38                 out0 = x + coef*y
39                 out1 = x - coef*y
40         finally:
41             create tDone
42
43 rule Top:
44     var fft_size: Int(2048) # Parameterizable
45     var f: FFT(fft_size, Bits(16))
46     rule testbench1:
47         var k: Array(fft_size, Bits(16), preload='fft_inputs.
48             txt')
49         call f.fft(Input=k, Coefficients=k)

```

## B.2 MSP430 Code Listing

```

1  # This is only the control core
2  # There is no actual memory or register file implementation
3  # since I removed array indices completely.
4
5  class Instruction:
6      var v: Bits(48)
7      rule single_opcode<-(self):
8          return self.v[9:7]
9      rule single_bw<-(self):
10         return self.v[6]
11     rule single_ad<-(self):
12         return self.v[5:4]
13     rule single_dsreg<-(self):
14         return self.v[3:0]
15     rule is_single<-(self):
16         return self.v[15:10] == 4
17
18     rule opRRC<-(self):
19         return self.single_opcode() == 0
20     rule opSWPB<-(self):
21         return self.single_opcode() == 1

```



```

22     rule opRRA<-(self):
23         return self.single_opcode() == 2
24     rule opSXT<-(self):
25         return self.single_opcode() == 3
26     rule opPUSH<-(self):
27         return self.single_opcode() == 4
28     rule opCALL<-(self):
29         return self.single_opcode() == 5
30     rule opRETI<-(self):
31         return self.single_opcode() == 6
32
33     rule double_opcode<-(self):
34         return self.v[15:12]
35     rule double_sreg<-(self):
36         return self.v[11:8]
37     rule double_ad<-(self):
38         return self.v[7]
39     rule double_bw<-(self):
40         return self.v[6]
41     rule double_as<-(self):
42         return self.v[5:4]
43     rule double_dreg<-(self):
44         return self.v[3:0]
45     rule is_double<-(self):
46         return self.v[14] or self.v[15]
47
48     rule opMOV<-(self):
49         return self.double_opcode() == 4
50     rule opADD<-(self):
51         return self.double_opcode() == 5
52     rule opADDC<-(self):
53         return self.double_opcode() == 6
54     rule opSUBC<-(self):
55         return self.double_opcode() == 7
56     rule opSUB<-(self):
57         return self.double_opcode() == 8
58     rule opCMP<-(self):
59         return self.double_opcode() == 9
60     rule opDADD<-(self):
61         return self.double_opcode() == 10
62     rule opBIT<-(self):
63         return self.double_opcode() == 11
64     rule opBIC<-(self):
65         return self.double_opcode() == 12
66     rule opBIS<-(self):
67         return self.double_opcode() == 13
68     rule opXOR<-(self):
69         return self.double_opcode() == 14
70     rule opAND<-(self):
71         return self.double_opcode() == 15
72
73     rule opJNE<-(self): # JNE/JNZ
74         return self.jump_condition() == 0

```

```

75     rule opJEQ<-(self): # JEQ/JZ
76         return self.jump_condition() == 1
77     rule opJNC<-(self): # JNC/JLO
78         return self.jump_condition() == 2
79     rule opJC<-(self): # JC/JHS
80         return self.jump_condition() == 3
81     rule opJN<-(self):
82         return self.jump_condition() == 4
83     rule opJGE<-(self):
84         return self.jump_condition() == 5
85     rule opJL<-(self):
86         return self.jump_condition() == 6
87     rule opJMP<-(self):
88         return self.jump_condition() == 7
89
90     rule jump_opcode<-(self):
91         return self.v[15:13]
92     rule jump_condition<-(self):
93         return self.v[12:10]
94     rule jump_offset<-(self):
95         return (self.v[9:0]) | \
96             (self.v[9] << 10) | \
97             (self.v[9] << 11) | \
98             (self.v[9] << 12) | \
99             (self.v[9] << 13) | \
100            (self.v[9] << 14) | \
101            (self.v[9] << 15)
102
103     rule is_jump<-(self):
104         return self.v[15:13] == 1
105
106     rule next_word<-(self):
107         return self.v[31:15]
108     rule third_word<-(self):
109         return self.v[47:32]
110
111 class Status:
112
113     var carry: Bits(1)
114     var zero: Bits(1)
115     var negative: Bits(1)
116     var gie: Bits(1)
117     var overflow: Bits(1)
118
119     rule FullRegister<-(self):
120         return self.carry | (self.zero << 1) | (self.negative
121             << 2) | (self.gie << 3) | (self.overflow << 8)
122
123 class Memory:
124     var data: Addressable(size=65535, type=Bits(16))
125
126 rule TestbenchEnvironment:

```

```

127     var memory: Memory()
128     var instruction_limit: Bits(16)
129     var pc: Bits(16)
130
131     rule setupInstructionStream:
132         pc = 0
133         create tInitialize
134
135     var registers: Addressable(size=16, type=Bits(16))
136     var sp: Bits(16)
137     var sr: Bits(16)
138     var status: Status()
139     var pc_offset: Bits(16)
140
141     rule initialize(tInitialize):
142         sp = 0
143         sr = 0
144         status.carry = 0
145         status.zero = 0
146         status.negative = 0
147         status.gie = 0
148         status.overflow = 0
149         create tGetNextInstruction
150
151     rule getNextInstruction(tGetNextInstruction):
152         print "current pc=", pc
153         var i: Instruction()
154         if pc <= instruction_limit:
155             create tInstruction
156
157     rule MSP430(tInstruction):
158         var instr: Instruction()
159         rule GetFirstWord:
160             instr.v = memory.data[pc]
161             create tStartInstruction
162
163     rule InstructionStream(tStartInstruction):
164         var src_op, dest_op: Bits(16)
165         var src_pc_offset, dest_pc_offset: Bits(2)
166
167         var src, dest: Bits(4)
168         var smode, dmode: Bits(2)
169
170     rule Decode:
171         rule DetermineType:
172             print "Instruction value: ", hex(instr.v)
173             pc_offset = 1
174             if instr.is_jump():
175                 print "    Jump operation"
176                 create tExecuteJump
177             elif instr.is_single():
178                 print "    Single operation"
179                 create tDecodeSingle

```

```

180         elif instr.is_double():
181             print " Double operation"
182             create tDecodeDouble
183         else:
184             create tDecodeError
185
186     rule DecodeSingle(tDecodeSingle):
187         src = instr.single_dsreg()
188         smode = instr.single_ad()
189
190         if not instr.opRETI():
191             create tGetSourceOperand
192         else:
193             # For RETI instructions, we just execute
194             # them directly. We just pretend
195             # that the source operation was completed
196             # by creating the token here.
197             src_op = 0
198             src_pc_offset = 1
199             create tSourceReady
200
201     rule DecodeDouble(tDecodeDouble):
202         src = instr.double_sreg()
203         smode = instr.double_as()
204         create tGetSourceOperand
205
206         if instr.opMOV():
207             create tDecodeMOV
208         else:
209             dest = instr.double_dreg()
210             dmode = instr.double_ad()
211             create tGetDestOperand
212
213     rule DecodeMOV(tDecodeMOV):
214         # If it's a MOV instruction, we do not need
215         # to read the destination
216         # so we just create the token here.
217         if smode == 1:
218             dest_pc_offset = 1
219         else:
220             dest_pc_offset = 0
221         dest_op = 0
222         create tDestReady
223
224 # end rule Decode
225
226     rule GetSourceOperand(tGetSourceOperand):
227         var srcaddr: Bits(16)
228
229     rule DetermineSourceAddressing:
230         # smode == 0: direct register smode

```

```

228         # smode == 1: indirect, register + offset,
           where the offset is in the next
           instruction word
229         #         unless the register is SR (
           status reg): then it's an absolute
           address
230         # smode == 2: indirect register, but without
           an offset
231         # smode == 3: used with regular registers is
           the same as smode==2, but it
           autoincrements
232         #         by 1 for byte instructions and
           by 2 for word instructions
233         #         When used with PC, the next
           instruction word will be used as an
           immediate constant
234         src_pc_offset = 0
235
236         # first deal with constant generation
237         if (src == 2 and smode > 1) or src == 3:
238             # note: if src==2 (status reg) and smode
           (AS) == 01, then it's absolute smode
239             #         if src==2 (SR) and smode (AS) ==
           0, then it's a regular status reg read
240             #         otherwise: it's the constant
           generator
241             create tConstantGenerator
242         else:
243             if smode == 0:
244                 print "        Source is register, r:",
           src
245                 create tSourceIsRegister
246             elif smode == 1:
247                 if src == 2: # status register
248                     print "        Source is absolute"
249                     create tSourceIsAbsolute
250                 else:
251                     print "        Source is indexed"
252                     create tSourceIsIndexed
253             elif smode == 2:
254                 print "        Source is indirect"
255                 create tSourceIsIndirect
256             elif smode == 3:
257                 if src == 0: # PC -> immediate
258                     print "        Source is immediate"
259                     create tSourceIsImmediate
260                 else:
261                     print "        Source is indirect
           autoincrement"
262                     create tSourceIsIndirect
263
264         rule SourceRegister(tSourceIsRegister):
265             if src == 0: # PC

```

```

266         src_op = pc
267         create tSourceDone
268     elif src == 1: # Stack Pointer
269         src_op = sp
270         create tSourceDone
271     elif src == 2: # Status Pointer
272         src_op = status.FullRegister()
273         create tSourceDone
274     else:
275         # regular register lookup
276         src_op = registers[src]
277         create tSourceDone
278
279     rule SourceAbsolute(tSourceIsAbsolute):
280         # address is stored in the next word
281         srcaddr = memory.data[pc + 1]
282         src_pc_offset = src_pc_offset + 1
283         create tMemoryLookupSource
284
285     rule SourceIndexed(tSourceIsIndexed):
286         var index_offset: Bits(16)
287         var reg_offset: Bits(16)
288         rule SourceIdxReadIndex:
289             index_offset = memory.data[pc + 1]
290             create tSourceIdxIndexReady
291         rule SourceIdxReg:
292             reg_offset = registers[src]
293             create tSourceIdxRegReady
294         rule SourceIdxMemRead(tSourceIdxIndexReady
295             and tSourceIdxRegReady):
296             src_op = memory.data[reg_offset +
297                 index_offset]
298             src_pc_offset = src_pc_offset + 1
299             create tSourceDone
300
301     rule SourceIndirect(tSourceIsIndirect):
302         var addr: Bits(16)
303         rule SourceIndReadAddr:
304             addr = memory.data[pc + 1]
305             create tSourceIndMemRead
306         rule SourceIndMemRead(tSourceIndMemRead):
307             src_op = memory.data[addr]
308             src_pc_offset = src_pc_offset + 1
309             create tSourceDone
310
311     rule SourceImmediate(tSourceIsImmediate):
312         src_op = memory.data[pc + 1]
313         src_pc_offset = src_pc_offset + 1
314         create tSourceDone
315
316     rule ConstantGenerator(tConstantGenerator):
317         if src == 2:
318             # status register

```

```

317         if smode == 0:
318             src_op = status.FullRegister()
319             print "Error: This should not have
                been reached."
320             create tDecodeError
321             # actual constants (result is determined
                by addressing smode)
322             elif smode == 1:
323                 src_op = 0
324             elif smode == 2:
325                 src_op = 4
326             elif smode == 3:
327                 src_op = 8
328         elif src == 3:
329             # more constants, again determined by
                addressing smode
330             if smode == 0:
331                 src_op = 0
332             elif smode == 1:
333                 src_op = 1
334             elif smode == 2:
335                 src_op = 2
336             elif smode == 3:
337                 src_op = 0xFFFF
338         create tSourceDone
339
340         rule SourceMemory(tMemoryLookupSource):
341             src_op = memory.data[srcaddr]
342             create tSourceDone
343
344         rule printSourceOperand(tSourceDone):
345             print "    Source operand: ", src_op
346             create tSourceReady
347
348     # end rule GetSourceOperand
349     rule GetDestOperand(tGetDestOperand):
350         var destaddr: Bits(16)
351
352         rule DetermineDestAddressing:
353             dest_pc_offset = 0
354
355             if dmode == 0:
356                 print "    Dest is register, r:", dest
357                 create tDestIsRegister
358             elif dmode == 1:
359                 if dest == 2: # status register
360                     print "    Dest is absolute"
361                     create tDestIsAbsolute
362                 else:
363                     print "    Dest is indexed"
364                     create tDestIsIndexed
365             else:
366                 print "Dest is UNKNOWN"

```

```

367         create tDecodeError
368
369     rule DestRegister(tDestIsRegister):
370         if dest == 0: # PC
371             dest_op = pc
372             create tDestReadDone
373         elif dest == 1: # Stack Pointer
374             dest_op = sp
375             create tDestReadDone
376         elif dest == 2: # Status Pointer
377             dest_op = status.FullRegister()
378             create tDestReadDone
379         else:
380             # regular register lookup
381             dest_op = registers[dest]
382             create tDestReadDone
383
384     rule DestAbsolute(tDestIsAbsolute):
385         # address is stored in the next word
386         destaddr = memory.data[pc + 1]
387         dest_pc_offset = 1
388         create tMemoryLookupDest
389
390     rule DestIndexed(tDestIsIndexed):
391         var index_offset: Bits(16)
392         var reg_offset: Bits(16)
393         rule DestIdxReadIndex:
394             index_offset = memory.data[pc + 1]
395             create tDestIdxIndexReady
396         rule DestIdxReg:
397             reg_offset = registers[dest]
398             create tDestIdxRegReady
399         rule DestIdxMemRead(tDestIdxIndexReady and
400             tDestIdxRegReady):
401             dest_op = memory.data[reg_offset +
402                 index_offset]
403             dest_pc_offset = 1
404             create tDestReadDone
405
406     rule DestMemory(tMemoryLookupDest):
407         dest_op = memory.data[destaddr]
408         create tDestReadDone
409
410     rule printDestOperand(tDestReadDone):
411         print "Dest operand: ", dest_op
412         create tDestReady
413 # end GetDestOperand
414
415     rule ExecuteJump(tExecuteJump):
416         # =====
417         #     Jump Operations
418         # =====
419         print "JMP Operation"

```



```

418         if instr.opJNE() and status.zero == 0:
419             pc_offset = instr.jump_offset() + 1
420         elif instr.opJEQ() and status.zero == 1:
421             pc_offset = instr.jump_offset() + 1
422         elif instr.opJNC() and status.carry == 0:
423             pc_offset = instr.jump_offset() + 1
424         elif instr.opJC() and status.carry == 1:
425             pc_offset = instr.jump_offset() + 1
426         elif instr.opJN() and status.negative == 1:
427             pc_offset = instr.jump_offset() + 1
428         elif instr.opJGE() and status.negative ==
             status.overflow:
429             pc_offset = instr.jump_offset() + 1
430         elif instr.opJL() and status.negative != status
             .overflow:
431             pc_offset = instr.jump_offset() + 1
432         elif instr.opJMP():
433             pc_offset = instr.jump_offset() + 1
434         else:
435             pc_offset = 1
436         create tExecutionDone
437
438     var write_src      : Bits(4)
439     var write_mode    : Bits(2)
440     var write_bw      : Bits(1)
441     var write_pc_offset: Bits(2)
442     var result        : Bits(17)
443
444     rule Execute(tSourceReady and tDestReady):
445
446         rule DetermineExecutionType:
447             # first combine pc offsets
448             pc_offset = pc_offset + dest_pc_offset +
             src_pc_offset
449             print "pc_offset =", pc_offset, "
             dest_pc_offset =", dest_pc_offset, "
             src_pc_offset =", src_pc_offset
450             if instr.is_single():
451                 create tExecuteSingle
452             elif instr.is_double():
453                 create tExecuteDouble
454             else:
455                 create tDecodeError
456
457         # =====
458         #     Single Operations
459         # =====
460         rule ExecuteSingle(tExecuteSingle):
461             rule DetermineSingleOperation:
462                 if instr.opRRC():
463                     create tRRC
464                 elif instr.opSWPB():
465                     create tSWPB

```

```

466         elif instr.opRRA():
467             create tRRA
468         elif instr.opSXT():
469             create tSXT
470         elif instr.opPUSH():
471             create tPUSH
472         elif instr.opCALL():
473             create tCALL
474         elif instr.opRETI():
475             create tRETI
476         else:
477             create tDecodeError
478
479     # Single ops
480     rule SXT(tSXT):
481         rule SignExtend:
482             result = (src_op[7] << 15) | \
483                     (src_op[7] << 14) | \
484                     (src_op[7] << 13) | \
485                     (src_op[7] << 12) | \
486                     (src_op[7] << 11) | \
487                     (src_op[7] << 10) | \
488                     (src_op[7] << 9) | \
489                     (src_op[7] << 8) | \
490                     src_op[7:0]
491             create tSXTStatus
492         rule SXTStatus(tSXTStatus):
493             status.carry = (result != 0)
494             status.zero = (result == 0)
495             status.negative = result[15]
496             status.overflow = 0
497             create tDestinationIsSource
498
499     rule RRC(tRRC):
500         rule ShiftAndRotate:
501             if instr.single_bw(): # byte
502                 result = (status.carry << 7) | (
503                     src_op >> 1) & 0x7F
504             else: # word
505                 result = (status.carry << 15) | (
506                     src_op >> 1)
507             create tRRCStatus
508         rule RRCStatus(tRRCStatus):
509             status.carry = src_op[0] # carry
510             status.zero = (result == 0)
511             status.negative = result[15]
512             status.overflow = 0
513             create tDestinationIsSource
514
515     rule RRA(tRRA):
516         rule RotateRightArith:
517             if instr.single_bw():

```

## Appendix B. FFT and MSP430 Code Listing

---

```

516         result = (src_op & 0x80) | (src_op
517             [7:0] >> 1)
518     else:
519         result = (src_op & 0x8000) | (
520             src_op[15:0] >> 1)
521     create tRRASStatus
522     rule RRASStatus(tRRASStatus):
523         status.carry = src_op[0]
524         status.zero = (result == 0)
525         if instr.single_bw():
526             status.negative = result[7]
527         else:
528             status.negative = result[15]
529         status.overflow = 0
530         create tDestinationIsSource
531
532     rule SWPB(tSWPB):
533         result = (src_op[7:0] << 8) | (src_op
534             [15:8] >> 8)
535         create tDestinationIsSource
536
537     rule PUSH(tPUSH):
538         sp = sp - 2
539         memory.data[sp] = src_op
540         create tExecutionDone
541
542     rule CALL(tCALL):
543         sp = sp - 2
544         memory.data[sp] = pc
545         pc = src_op
546         create tExecutionDone
547
548     rule RETI(tRETI):
549         # restore status register
550         var status_reg: Bits(16)
551         rule RETILoad:
552             status_reg = memory.data[sp]
553             create tRETIload
554         rule RETIExc(tRETIload):
555             status.carry = status_reg[0]
556             status.zero = status_reg[1]
557             status.negative = status_reg[2]
558             status.overflow = status_reg[8]
559
560             pc = memory.data[sp + 2]
561             sp = sp + 4
562             create tExecutionDone
563
564     # =====
565     #     Double Operations
566     # =====
567     rule ExecuteDouble(tExecuteDouble):
568         rule DetermineDoubleOperation:

```

```

566         if instr.opMOV():
567             create tMOV
568         elif instr.opADD():
569             create tADD
570         elif instr.opADDC():
571             create tADDC
572         elif instr.opSUB():
573             create tSUB
574         elif instr.opSUBC():
575             create tSUBC
576         elif instr.opDADD():
577             create tDADD
578         elif instr.opBIT():
579             create tBIT
580         elif instr.opCMP():
581             create tCMP
582         else:
583             create tDecodeError
584
585     # Double ops
586     rule MOV(tMOV):
587         print "MOV operation."
588         result = src_op
589         create tWriteDestination
590
591     rule ADD(tADD):
592         print "ADD operation. ", src_op, " + ",
593             dest_op
594         result = src_op + dest_op
595         create tUpdateStatusWriteDest
596
597     rule ADDC(tADDC):
598         print "ADDC operation."
599         result = src_op + dest_op + status.carry
600         create tUpdateStatusWriteDest
601
602     rule SUB(tSUB):
603         print "SUB operation."
604         result = src_op - dest_op
605         create tUpdateStatusWriteDest
606
607     rule CMP(tCMP):
608         print "CMP operation => ", src_op, "-",
609             dest_op, " = ", (src_op - dest_op)
610         result = src_op - dest_op
611         create tUpdateStatusWriteDest
612
613     rule SUBC(tSUBC):
614         print "SUBC operation."
615         result = src_op - dest_op + status.carry
616         create tUpdateStatusWriteDest
617
618     rule DADD(tDADD):

```

```

617         print "DADD operation."
618         # Treat the number as a signed BCD
619         var c0, c1, c2, c3: Bits(1)
620         rule DADD_digit1:
621             var m: Bits(4)
622             rule DADD_d1_offset:
623                 m = src_op[3:0] + dest_op[3:0]
624                 create tDADD_d1_offset
625             rule DADD_d1(tDADD_d1_offset):
626                 print "DEBUG m = ",m, "m <= 9:", m
627                 <= 9
628                 if m <= 9:
629                     result[3:0] = m
630                     c0 = 0
631                 else:
632                     result[3:0] = m - 10
633                     c0 = 1
634                 create tDADD_digit2
635             rule DADD_digit2(tDADD_digit2):
636                 var m: Bits(4)
637                 rule DADD_d2_offset:
638                     m = src_op[7:4] + dest_op[7:4] + c0
639                 create tDADD_d2_offset
640             rule DADD_d2(tDADD_d2_offset):
641                 if m <= 9:
642                     result[7:4] = m
643                     c1 = 0
644                 else:
645                     result[7:4] = m - 10
646                     c1 = 1
647                 if instr.double_bw(): # if it's a
648                     word...
649                     create tDADD_digit3
650                 else:
651                     create tWriteDestination
652             rule DADD_digit3(tDADD_digit3):
653                 var m: Bits(4)
654                 rule DADD_d3_offset:
655                     m = src_op[11:8] + dest_op[11:8] +
656                     c1
657                 create tDADD_d3_offset
658             rule DADD_d3(tDADD_d3_offset):
659                 if m <= 9:
660                     result[11:8] = m
661                     c2 = 0
662                 else:
663                     result[11:8] = m - 10
664                     c2 = 1
665                 create tDADD_digit4
666             rule DADD_digit4(tDADD_digit4):
667                 var m: Bits(4)
668                 rule DADD_d4_offset:

```

```

666         m = src_op[15:12] + dest_op[15:12]
667             + c2
668         create tDADD_d4_offset
669     rule DADD_d4(tDADD_d4_offset):
670         if m <= 9:
671             result[15:12] = m
672         else:
673             result[15:12] = m - 10
674         create tUpdateStatusWriteDest
675
676     rule BIT(tBIT):
677         print "SUBC operation."
678         result = src_op - dest_op + status.carry
679         status.carry = result[16]
680         create tUpdateStatusWriteDest
681
682     rule UpdateStatusAndWriteDestination(
683         tUpdateStatusWriteDest):
684         if instr.double_bw():
685             status.zero = (result[15:0] == 0)
686             status.carry = result[16]
687             status.overflow = ((src_op[15] &
688                 dest_op[15]) & ~result[15]) | ((~
689                 src_op[15] & ~dest_op[15]) & result
690                 [15])
691             status.negative = result[15]
692         else:
693             status.zero = (result[7:0] == 0)
694             status.carry = result[8]
695             status.overflow = ((src_op[7] &
696                 dest_op[7]) & ~result[7]) | ((~
697                 src_op[7] & ~dest_op[7]) & result
698                 [7])
699             status.negative = result[7]
700             result = result & 0xFF
701         if not instr.opCMP():
702             print "*** result = ", result
703             create tWriteDestination
704         else:
705             create tExecutionDone
706
707     # =====
708     # Write Destination
709     # =====
710     rule DestinationIsSource(tDestinationIsSource):
711         write_src = instr.single_dsreg()
712         write_mode = instr.single_ad()
713         write_bw = instr.single_bw()
714         write_pc_offset = 0
715         create tWriteback
716
717     rule WriteDoubleResult(tWriteDestination):
718         write_src = instr.double_dreg()

```

```

711         write_mode = instr.double_ad()
712         write_bw = instr.double_bw()
713         write_pc_offset = 0
714         create tWriteback
715
716     # end Execute
717
718     # write back
719     rule Writeback(tWriteback):
720         rule DetermineWritebackMode:
721             if (write_src == 2 and write_mode > 1) or
722                 write_src == 3:
723                 create tCGError # attempt to write to the
724                     CG
725             else:
726                 if write_mode == 0:
727                     print "Writeback is register, r:",
728                         write_src
729                     create tWritebackIsRegister
730                 elif write_mode == 1:
731                     if write_src == 2: # status register
732                         print "Writeback is absolute"
733                         create tWritebackIsAbsolute
734                     elif write_src == 0: # pc
735                         print "Writeback is symbolic"
736                         create tWritebackIsSymbolic
737                     else:
738                         print "Writeback is indexed"
739                         create tWritebackIsIndexed
740
741         rule WritebackIsRegister(tWritebackIsRegister):
742             if write_src == 0: # PC
743                 pc = result
744                 create tWritebackDone
745             elif write_src == 1: # Stack Pointer
746                 sp = result
747                 create tWritebackDone
748             elif write_src == 2: # Status Pointer
749                 status.carry = result[0]
750                 status.zero = result[1]
751                 status.negative = result[2]
752                 status.gie = result[3]
753                 status.overflow = result[8]
754                 create tWritebackDone
755             else:
756                 # regular register write
757                 registers[write_src] = result
758                 print "Writing ", result, " to registers
759                     [", write_src, "]"
760                 create tWritebackDone
761
762         rule WritebackIsAbsolute(tWritebackIsAbsolute):
763             var addr: Bits(16)

```

```

760         rule WritebackAbsReadAddr:
761             addr = memory.data[pc + write_pc_offset]
762             create tWritebackAbsReadMem
763         rule WritebackAbsReadMem(
764             tWritebackAbsReadMem):
765             memory.data[addr] = result
766             print "Memory write", result, "to address
767                 ", hex(addr)
768             create tWritebackDone
769
770     rule WritebackIsSymbolic(tWritebackIsSymbolic):
771         var index_offset: Bits(16)
772         var addr: Bits(16)
773         rule WritebackSymReadIndex:
774             index_offset = memory.data[pc +
775                 write_pc_offset]
776             create tWritebackSymReadAddr
777         rule WritebackSymReadAddr(
778             tWritebackSymReadAddr):
779             addr = memory.data[pc + index_offset]
780             create tWritebackSymReadMem
781         rule WritebackSymReadMem(
782             tWritebackSymReadMem):
783             memory.data[addr] = result
784             print "Memory write", result, "to
785                 symbolic address", hex(addr)
786             create tWritebackDone
787
788     rule WritebackIsIndexed(tWritebackIsIndexed):
789         var index_offset: Bits(16)
790         var addr: Bits(16)
791         rule WritebackIdxReadIndex:
792             index_offset = memory.data[pc +
793                 write_pc_offset]
794             create tWritebackIdxReadAddr
795         rule WritebackIdxReadAddr(
796             tWritebackIdxReadAddr):
797             addr = registers[write_src] +
798                 index_offset
799             create tWritebackIdxReadMem
800         rule WritebackIdxReadMem(
801             tWritebackIdxReadMem):
802             memory.data[addr] = result
803             print "Indexed memory.data write", result
804                 , "to address", hex(addr)
805             create tWritebackDone
806
807     rule WritebackCleanup(tWritebackDone):
808         create tExecutionDone
809
810 # end rule InstructionStream
811
812 rule DecodeError(tDecodeError):

```



```
802         print "Decode error for instruction: ", instr.v,  
            hex(instr.v)  
803  
804     rule CGError(tCGError):  
805         print "Decode error [write to CG] for instruction:  
            ", instr.v, hex(instr.v)  
806  
807     rule Cleanup(tExecutionDone):  
808         create tInstructionDone  
809  
810     rule InstructionDone(tInstructionDone):  
811         pc = pc + pc_offset  
812         print "Instruction done. pc=", pc, "pc-offset=",  
            hex(pc_offset)
```

# Appendix C

## Tables of Matrix Multiplication Clustering

### C.1 Matrix Multiplication Size Sweep Data

Software Pipeline Depth	# Accelerators	BRAM Size	SPM Size	N	M	P	# Nodes	Schedule Length	Clusters	Runtime (s)
2	2	128	8	8	8	12	1696	2321	2	0.28
2	2	128	16	8	8	12	1696	2321	2	0.27
2	2	128	32	8	8	12	1696	2321	2	0.28
2	2	128	64	8	8	12	1696	2321	2	0.27
2	2	256	8	8	8	12	1696	2317	1	0.27
2	2	256	16	8	8	12	1696	2317	1	0.26
2	2	256	32	8	8	12	1696	2317	1	0.26
2	2	256	64	8	8	12	1696	2317	1	0.26
2	2	512	8	8	8	12	1696	2317	1	0.26
2	2	512	16	8	8	12	1696	2317	1	0.27
2	2	512	32	8	8	12	1696	2317	1	0.27
2	2	512	64	8	8	12	1696	2317	1	0.26
2	2	128	8	10	2	16	692	972	2	0.11
2	2	128	16	10	2	16	692	972	2	0.10
2	2	128	32	10	2	16	692	972	2	0.11

Appendix C. Tables of Matrix Multiplication Clustering

Software Pipeline Depth	# Ac- celera- tors	BRAM Size	SPM Size	N	M	P	# Nodes	Schedule Length	Clusters	Runtime (s)
2	2	128	64	10	2	16	692	972	2	0.11
2	2	256	8	10	2	16	692	968	1	0.10
2	2	256	16	10	2	16	692	968	1	0.10
2	2	256	32	10	2	16	692	968	1	0.10
2	2	256	64	10	2	16	692	968	1	0.11
2	2	512	8	10	2	16	692	968	1	0.11
2	2	512	16	10	2	16	692	968	1	0.11
2	2	512	32	10	2	16	692	968	1	0.10
2	2	512	64	10	2	16	692	968	1	0.10
2	2	128	8	16	8	16	4352	6170	4	0.83
2	2	128	16	16	8	16	4352	6169	4	0.76
2	2	128	32	16	8	16	4352	6170	4	0.77
2	2	128	64	16	8	16	4352	6169	4	0.76
2	2	256	8	16	8	16	4352	6163	2	0.75
2	2	256	16	16	8	16	4352	6161	2	0.75
2	2	256	32	16	8	16	4352	6161	2	0.76
2	2	256	64	16	8	16	4352	6161	2	0.76
2	2	512	8	16	8	16	4352	6157	1	0.70
2	2	512	16	16	8	16	4352	6157	1	0.70
2	2	512	32	16	8	16	4352	6157	1	0.70
2	2	512	64	16	8	16	4352	6157	1	0.71
2	2	128	8	32	16	16	17152	25642	7	3.21
2	2	128	16	32	16	16	17152	25124	7	3.19
2	2	128	32	32	16	16	17152	24620	8	3.24
2	2	128	64	32	16	16	17152	24619	8	3.27
2	2	256	8	32	16	16	17152	25628	4	3.15
2	2	256	16	32	16	16	17152	25114	4	3.16
2	2	256	32	32	16	16	17152	24603	4	3.22
2	2	256	64	32	16	16	17152	24603	4	3.22
2	2	512	8	32	16	16	17152	25618	2	3.15
2	2	512	16	32	16	16	17152	25106	2	3.16
2	2	512	32	32	16	16	17152	24595	2	3.18
2	2	512	64	32	16	16	17152	24595	2	3.13

## C.2 Software-Pipelining Data

Software Pipeline Depth	# Accel	BRAM Size	SPM Size	N	M	P	# Nodes	Schedule Length	Clusters	Runtime (s)	Average Utility
3	3	128	32	14	16	12	5792	8092	4	1.09	0.66
4	3	128	32	14	16	12	5792	16181	4	1.15	0.66
5	3	128	32	14	16	12	5792	16181	4	1.15	0.66
6	3	128	32	14	16	12	5792	16181	4	1.15	0.66
7	3	128	32	14	16	12	5792	24271	4	1.20	0.66
8	3	128	32	14	16	12	5792	24271	4	1.20	0.66
3	4	128	32	14	16	12	5792	8092	4	1.10	0.66
4	4	128	32	14	16	12	5792	8091	4	1.10	0.66
5	4	128	32	14	16	12	5792	16181	4	1.17	0.66
6	4	128	32	14	16	12	5792	16181	4	1.17	0.66
7	4	128	32	14	16	12	5792	16181	4	1.17	0.66
8	4	128	32	14	16	12	5792	16181	4	1.18	0.66
3	5	128	32	14	16	12	5792	8091	4	1.11	0.66
4	5	128	32	14	16	12	5792	8091	4	1.11	0.66
5	5	128	32	14	16	12	5792	8091	4	1.12	0.66
6	5	128	32	14	16	12	5792	16181	4	1.19	0.66
7	5	128	32	14	16	12	5792	16181	4	1.18	0.66
8	5	128	32	14	16	12	5792	16181	4	1.19	0.66
3	6	128	32	14	16	12	5792	8095	5	1.13	0.66
4	6	128	32	14	16	12	5792	8092	4	1.13	0.66
5	6	128	32	14	16	12	5792	8091	4	1.12	0.66
6	6	128	32	14	16	12	5792	8091	4	1.13	0.66
7	6	128	32	14	16	12	5792	16181	4	1.21	0.66
8	6	128	32	14	16	12	5792	16181	4	1.21	0.66
3	7	128	32	14	16	12	5792	8091	4	1.14	0.66
4	7	128	32	14	16	12	5792	8091	4	1.13	0.66
5	7	128	32	14	16	12	5792	8091	4	1.13	0.66
6	7	128	32	14	16	12	5792	8092	4	1.15	0.66
7	7	128	32	14	16	12	5792	8091	4	1.15	0.66
8	7	128	32	14	16	12	5792	16181	4	1.23	0.66
3	8	128	32	14	16	12	5792	8091	4	1.13	0.66

Appendix C. Tables of Matrix Multiplication Clustering

Software Pipeline Depth	# Accel	BRAM Size	SPM Size	N	M	P	# Nodes	Schedule Length	Clusters	Runtime (s)	Average Utility
4	8	128	32	14	16	12	5792	8091	4	1.15	0.66
5	8	128	32	14	16	12	5792	8091	4	1.14	0.66
6	8	128	32	14	16	12	5792	8091	4	1.16	0.66
7	8	128	32	14	16	12	5792	8091	4	1.14	0.66
8	8	128	32	14	16	12	5792	8092	4	1.15	0.66
3	3	128	32	14	16	12	5792	8092	4	1.09	0.66
4	3	128	32	14	16	12	5792	16181	4	1.15	0.66
5	3	128	32	14	16	12	5792	16181	4	1.15	0.66
6	3	128	32	14	16	12	5792	16181	4	1.15	0.66
7	3	128	32	14	16	12	5792	24271	4	1.20	0.66
8	3	128	32	14	16	12	5792	24271	4	1.20	0.66
3	4	128	32	14	16	12	5792	8092	4	1.10	0.66
4	4	128	32	14	16	12	5792	8091	4	1.10	0.66
5	4	128	32	14	16	12	5792	16181	4	1.17	0.66
6	4	128	32	14	16	12	5792	16181	4	1.17	0.66
7	4	128	32	14	16	12	5792	16181	4	1.17	0.66
8	4	128	32	14	16	12	5792	16181	4	1.18	0.66

# Appendix D

## Tables of FFT Clustering

### D.1 FFT Size Sweep Data

Software Pipeline Depth	# Ac- celera- tors	BRAM Size	SPM Size	FFT Size	# Nodes	Schedule Length	Clusters	Runtime (s)
1	2	256	0	8192	114688	213195	49	23.87
1	2	256	8	8192	114688	205436	49	24.82
1	2	256	16	8192	114688	196926	49	24.13
1	2	256	32	8192	114688	191435	49	24.00
1	2	256	64	8192	114688	183804	49	23.59
1	2	512	0	8192	114688	213099	25	23.58
1	2	512	8	8192	114688	205107	25	24.29
1	2	512	16	8192	114688	196115	25	24.35
1	2	512	32	8192	114688	191371	25	24.21
1	2	512	64	8192	114688	183594	25	24.15
1	2	1024	0	8192	114688	213049	13	24.24
1	2	1024	8	8192	114688	204494	13	24.05
1	2	1024	16	8192	114688	196324	13	23.92
1	2	1024	32	8192	114688	191263	13	23.71
1	2	1024	64	8192	114688	183775	13	24.34

# Appendix E

## Tables of Large Pipelined DSP Example

The following tables list near-linear scalability up to million-node sizes for a multi-level pipelined complex DSP.

Software Pipeline Depth	# Accelerators	BRAM Size	SPM Size	P	Depth	# Nodes	Schedule Length	Clusters	Runtime (s)
2	2	2048	32	16	10	110080	166744	2	20.68
2	2	2048	32	16	12	132096	200092	2	24.92
2	2	2048	32	16	14	154112	233438	2	29.47
2	2	2048	32	32	10	788480	1199721	6	161.68
2	2	2048	32	32	12	946176	1439664	7	193.55
2	2	2048	32	32	14	1103872	1679600	8	226.32
2	2	2048	64	16	10	110080	164060	2	20.73
2	2	2048	64	16	12	132096	196868	2	25.80
2	2	2048	64	16	14	154112	229676	2	29.20
2	2	2048	64	32	10	788480	1198919	6	162.86
2	2	2048	64	32	12	946176	1438697	7	197.29
2	2	2048	64	32	14	1103872	1678478	8	227.69
2	2	2048	128	16	10	110080	161443	2	20.71
2	2	2048	128	16	12	132096	193727	2	25.28
2	2	2048	128	16	14	154112	226011	2	29.02

*Appendix E. Tables of Large Pipelined DSP Example*

---

<b>Software Pipeline Depth</b>	<b># Accelerators</b>	<b>BRAM Size</b>	<b>SPM Size</b>	<b>P</b>	<b>Depth</b>	<b># Nodes</b>	<b>Schedule Length</b>	<b>Clusters</b>	<b>Runtime (s)</b>
2	2	2048	128	32	10	788480	1188278	6	159.17
2	2	2048	128	32	12	946176	1425916	7	193.36
2	2	2048	128	32	14	1103872	1663582	8	226.88