

Last issue:

For those of you who missed it, our last issue answered that question which has plagued us for so long, "Where did we come from?" The answer we came up with was, well, why should we tell you now? The next question to rear its ugly head was "What should we do with our lives now that we are here?" Should we plunge into the world of crass materialism, living for the pleasure principle?

Next Week:

What happens after you die?

Index:

Pick a major	2A
Kid's page	3A
Pose nude	4A
Nirvana	5A
Dear Amy	6A
Test yourself	7A
What's Next	8A

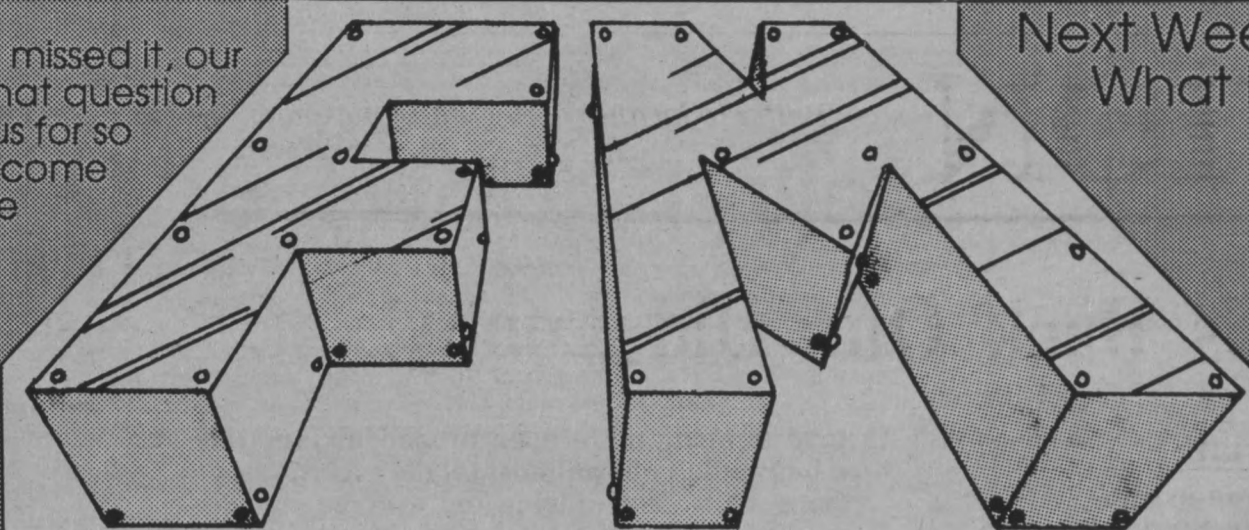

**BOLDLY
GOING WHERE
FOOLS FEAR
TO TREAD**

What Should We Do Now?

Do It

Twenty stupid things to do with your life.

- Listen to every tree fall so that each will make a noise.
- Make lists of things.
- Watch television shows with violent and/or sexual content and count the number of times the word "mom" is used.
- Preach celibacy to cockroaches.
- Send money to Westwood to help the locals keep up with fashion expectations.
- Follow Debbie Gibson around the country, seeing every concert and meeting other "Debb-heads."
- Make lots of money. Die.
- Drink water samples from around the world, hoping to get in on a class action toxics suit.
- Do Geraldo imitations.
- Respect Rodney Dangerfield.
- Pose nude in National Lampoon.
- Express your opposition to birth control by going to the drugstore and poking little holes in the condoms.
- Go to Pro/Anti abortion rallies and offer to mediate.
- Refuse to eat anything which was once alive.
- Right really long letters to the Nexus, rehashing the same arguments over and over.
- Wait for someone to ask you if you have a great idea for a movie.
- Go to the Antarctic, and pass yourself off to the penguins as Elvis.
- Keep alive the Ptolemaic (the Earth as center) view of the universe.
- Be the one person who decides what the Nexus opinion is.
- Rub your body with toxic waste, hoping to mutate into the Incredible Hulk.

— D. Jeffers

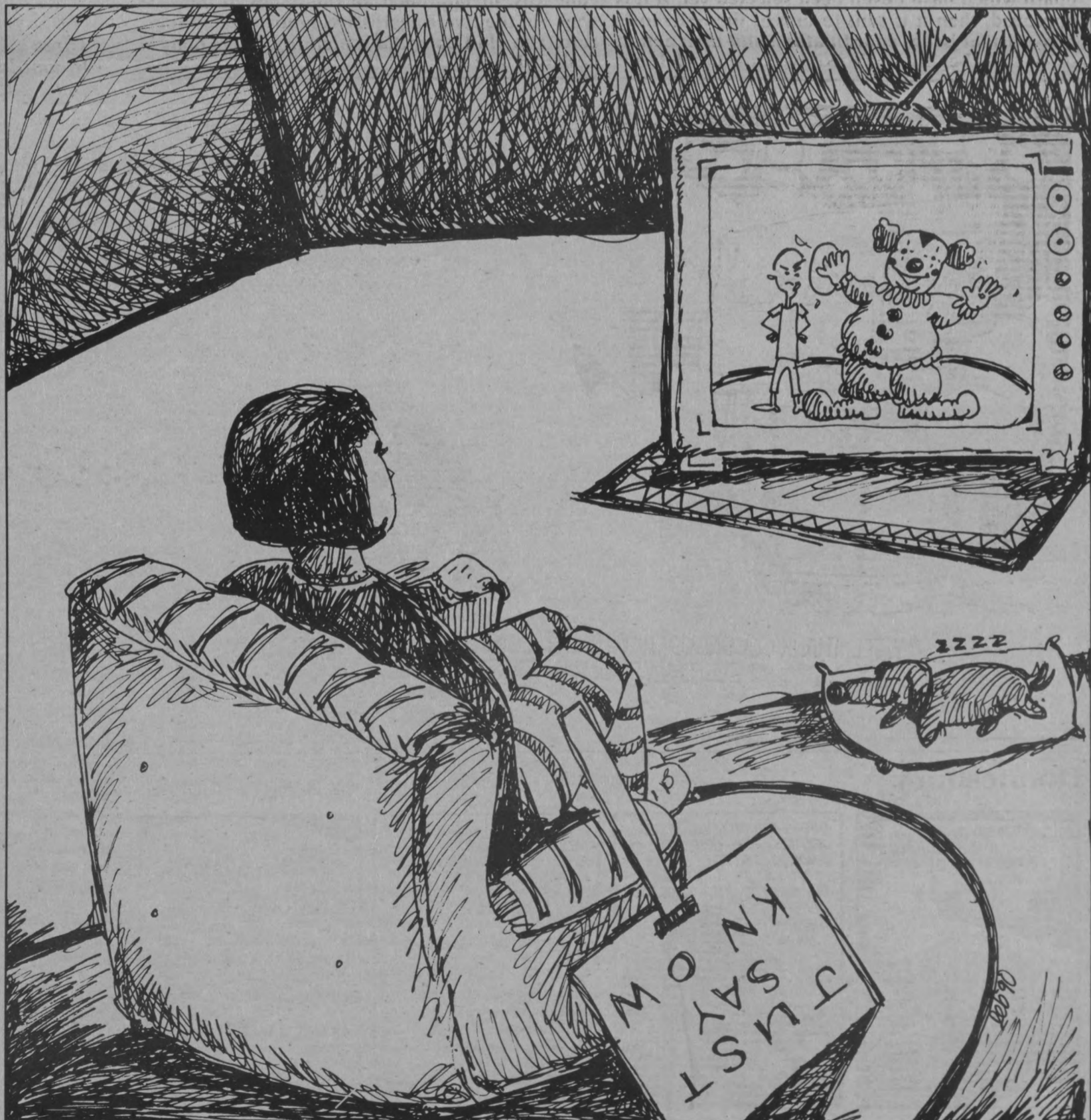



The Archetypes Of Good and Evil On TV

Since time began, one theory which has been used to examine our role in life is the part we play in the eternal struggle between good and evil, order and chaos. The modern university, with its anthropology, sociology and political science, can no longer handle this fundamental struggle. So society has had to find other methods of passing on its considerable mass of knowledge to the subject. The obvious way is the use of children's educational television.

Ernie and Bert; the icons of modern truth, these are more than harmless puppets teaching numbers and letters to our children, they are actually channels for the conflicting powers whose immortality lets our youngsters learn of both eternal opposition and eventual compromise.

Consider first how they appear. Bert is tall and regal; golden, the color of light; the stripes of his shirt reach heavenward, striving to sit with God; his head is triangular, representative of the Trinity; his hair is neatly styled, demonstrating his confidence of self; and though he has only one eyebrow, perhaps a disturbing trait, it symbolizes the internal consistency he embodies. Ernie, on the other hand, is short and squat; he is orange, the unrhythmic color, that of flames; his stripes stretch across, meaning that there are upward barriers when trying to follow his path; his round head, the vicious circle of damnation; his hair is wild and unkempt; and he has no

brows at all!

It is said that books cannot be judged by their covers, neither then can emissaries of spiritual powers. But their actions too shed light upon their true beings. Bert always has been kind and tolerant toward his nemesis' shenanigans, while Ernie acts on ways mischievous and, at times, subtly cruel. Bert is the member of the pair who supplies the answers, while Ernie constantly asks questions. An example from one episode: Bert was away vacationing and Ernie, perhaps lost in his aloneness, could not sleep. He called upon Bert in the middle of the night for refuge, and in his wisdom Bert suggested that Ernie count sheep. Could Ernie have conceived of this alone, given time? Perhaps. But Bert, with virtue and patience, gave aid.

From another episode, we see how the two need to put away their toys. In order to split the work fairly, Ernie offers to store all the toys which are red, large, and that have wheels and ladders; he puts away only one fire truck, leaving the rest for Bert. Ernie, then, is the archetype for Chaos; he leaves toys strewn about the house, and he cackles in his brilliance for making Bert replace them. Bert, by the same token, is Order. He is forced to align the debris of Ernie's wake, and though he sighs, he keeps his temper.

Bert is content, at peace with himself. The only discord in his life is caused by Ernie's roguish japes. Ernie is a tormented



TODD FRANCIS/Daily Nexus

soul, forced to mock and wag those around him for surrogate relief from his own miseries. By lowering them, he feels that he is higher.

Before you laugh this off as a joke, consider how the righteous and the selfish around you act. Is cruelty a fiction? Who is more noble, who more scurrilous? I cannot supply an answer for which is more powerful; I only report what I witness in the world

about me. There are saints and there are demons; often they are paired, like two sides of the same coin. Yet, like the Yin and the Yang, there is always potential for one within the other; with effort, perhaps it can be called out to overpower its foe, or perhaps the struggle will never end. But consider, reader, which is more like you? Are you a Bert? Or are you an Ernie?

— Chris Blunt

Life is Propagation

One of the traditional methods of achieving meaning in life is to have lots of kids, and hope one of them turns out like Gary Coleman (well almost like Gary Coleman). Say you think that the meaning of life is to become a doctor, save lives, and make big bucks, but you also know that becoming a doctor is a lot of work. Well, just have a couple kids and drive them day and night to succeed in fulfilling your dreams.

Purpose through kids does, after all, meet the ultimate criteria of (social) Darwinism. According to him, success includes competition for scarce resources and survival until you reproduce.

It also, coincidentally, meets the requirements of many religious groups. For instance, raising a passel of pious, contributing Episcopalian makes up for a lot of

Sunday football.

Of course, if children are your ultimate mode of self-expression, then you have to raise them as such. Teach them to respond to you as a person, teach them to be responsible, to do chores, to take out the garbage, to bring in the paper, to roll over, to play dead.

Being a parent is a well quantified role, one which is fully equipped with both comedy, a la Steve Martin, and tragedy, a la Oedipus Rex. Not only do you become a person, you get lower insurance rates, better credit, and a solid tax deduction.

Children may also be the key to immortality; having children is one way to carry on your name and memory. Obviously, you have to keep the kids off pot, otherwise your memories will be merged into a faint haze, competing constantly with

Grateful Dead concerts.

Without the kids, you have to try to be remembered by nephews and nieces and such. The best way to do this is to play "Will, will, whose in the will?"

Even if you have your own kids, long term immortality could remain elusive, after all, how many of your ancestors do you remember? If you have kids so that you will be immortal, then do you only exist for your great-great-great grandfather/grandmother? What if the population declines and more and more of us have to live on through the same descendants?

Can you imagine one survivor, the last human, trying to remember all his or her ancestors, who would otherwise pass away into nothingness?

... Hey,
the last
Daily Nexus
for the
Quarter is
Friday,
March 9!
Only 4 More
Advertising Days
Left!

Congratulations GAUCHOS!

Biggest Win in UCSB History...

MTC METROPOLITAN THEATRES

MOVIE HOTLINE 963-9503
Complete Program And Showtime Information For All Theatres
All programs, showtimes & restrictions subject to change without notice.

ARLINGTON 1317 State St. S.B.	The Hunt for Red October* 2:15, 5:10, 7:45, 10:15 Saturday at the Granada	George Winston Sat at 8 pm
GRANADA 3 1216 State St. S.B.	Field of Dreams 12, 3, 5:30, 8:10, 10:15 Fri & Mon only 12 & 3 Sat not at all Driving Miss Daisy 1:15, 3:30, 5:40, 8, 10:10	Stella 1, 3:10, 5:20, 7:50, 10 Sat no 7:50 S.B. Film Festival Opening Fri 7:30 Ken Branagh Mon 7
METRO 4 618 State St. S.B.	Men Don't Leave 12:10, 2:40, 5:10, 7:50, 10:20	My Left Foot 1:10, 3:20, 5:40, 8, 10:15
FIESTA 5 916 State St. S.B.	Rocky Horror Fri at Midnite Double Feature Crimes & Misdemeanors 1, 5:40, 10:10, Sat & Wed 1 only Dead Poet's Society 3:10, 7:45, Sat & Wed 3:10 only	Revenge 12:45, 3:05, 5:30, 8, 10:25 Flashback 5:30, 7:45, 10 Madhouse 1:30, 3:30, 5:30, 7:30, 9:30 S & S also 1, 3:15
PLAZA DE ORO TWIN 349 Hitchcock Way, S.B.	Where the Heart Is 5:35, 7:40, 9:40 Sat & Sun also 1:25, 3:30	Roger and Me 5:30, 7:30, 9:35 Sat & Sun also 1:15, 3:20
RIVIERA 2044 Alameda Padre Serra S.B.	Camille Claudel 6:45, 9:45 Sun also 3:45, Sat also 12:45, 3:45	
CINEMA TWIN 6050 Hollister Ave. Goleta	Glory 5, 7:30, 9:50 Sat & Sun also 12, 2:30	My Left Foot 5:15, 7:45, 9:55 Sat & Sun also 1, 3:10
FAIRVIEW TWIN 251 Fairview Goleta	Hard to Kill 5:45, 7:45, 9:45 Sat & Sun also 1:45, 3:45	Revenge 5, 7:30, 9:55 Sat & Sun also 12:30, 2:40
GOLETA 320 S. Kellogg Ave. Goleta	Driving Miss Daisy 5:30, 7:45, 9:45 Sat & Sun also 1:30, 3:30	
ARLINGTON TICKET AGENCY 1317 State St. S.B.	Hours: Mon.-Sat. 10-5:30 Sunday Noon-5 Information 963-4408	*No passes or bargain nights
SWAP MEET	EVERY SUNDAY 7am-3 pm Santa Barbara Twin Drive-in 907 S. Kellogg Ave., Goleta	964-9050 Swap Meet Information
GIFT SHOP	ARLINGTON COURT GIFT SHOP 1317 State Stree, next to the Arlington Theatre Open 12-8 pm Daily	966-3638 Gift Shop Information

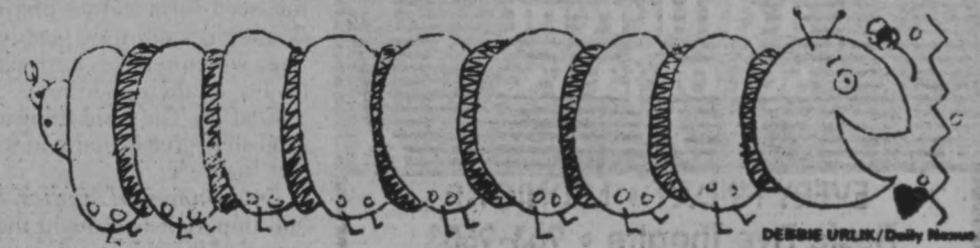
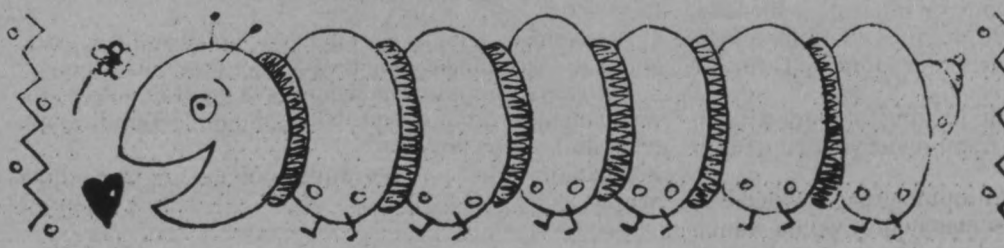

DEBBIE URLIK/Daily Nexus



Playboy's special "Girl's of the Reserve Book Room" pictorial will be auditioning soon, and we want you to express your inner being on our pages. The New Woman is self aware, self actualized, not afraid of her own sexuality.

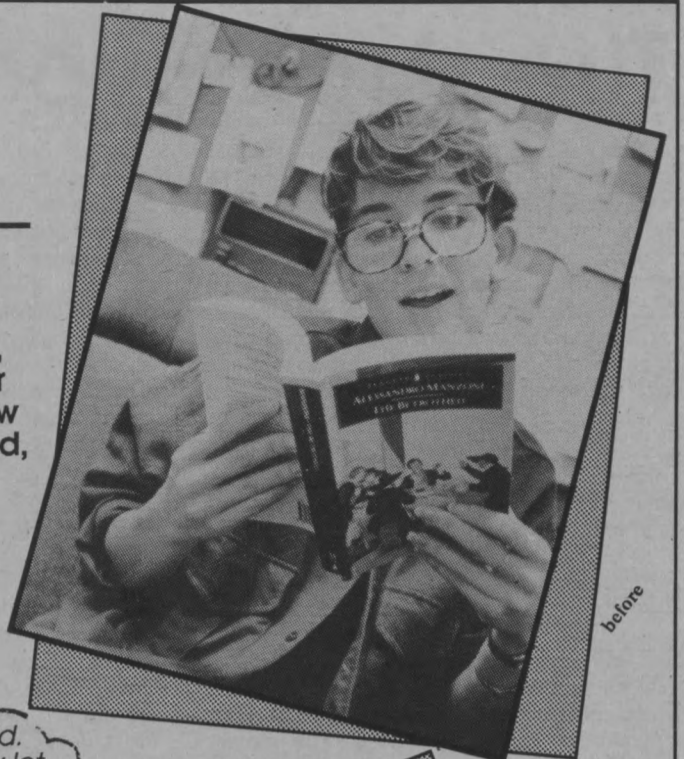
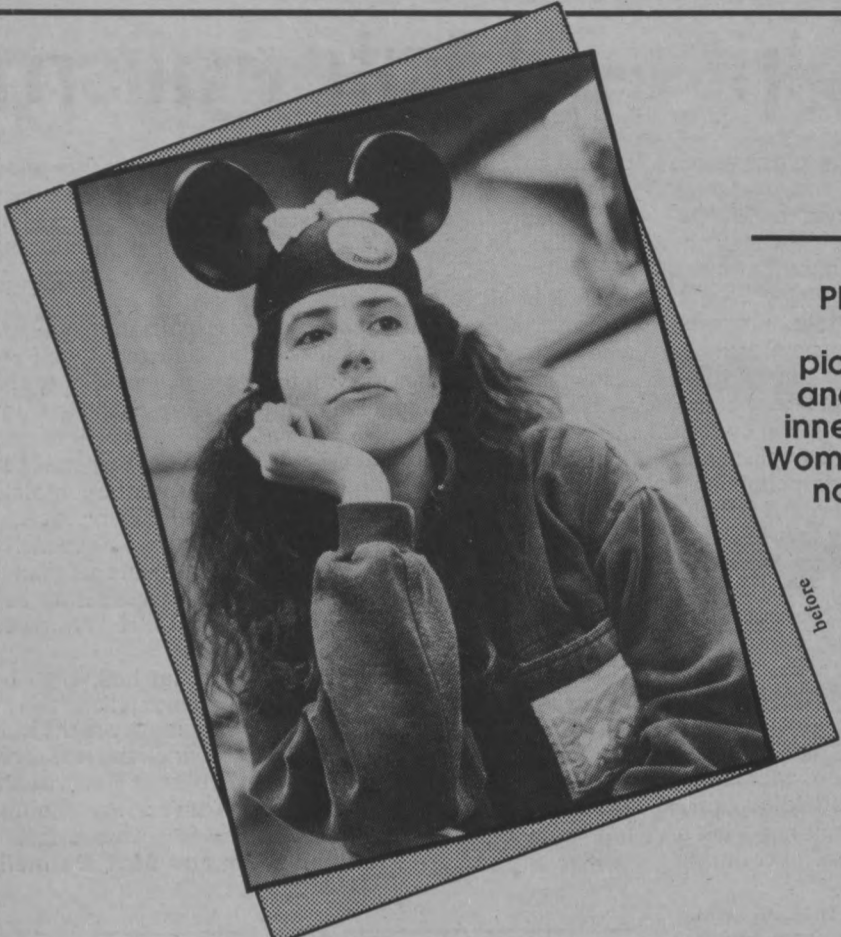

"Face it, I was from Bakersfield. When I posed for Playboy, they let me be from Lake Tahoe, and I got to add some letters to my name. Now I not only own my own business, I dominate my employees."
-Amoiria Kolliness



"Sure, I'm a feminist, but they said a feminist was just a woman who couldn't get a date. Well, I'm not just a feminist, I'm a woman. Posing for Playboy has taught me that I could be both, that I could hang naked from thousands of bathroom walls and still retain my dignity. And I got more strange letters in my name than Amy"
-Andreikkata Blakkshatia

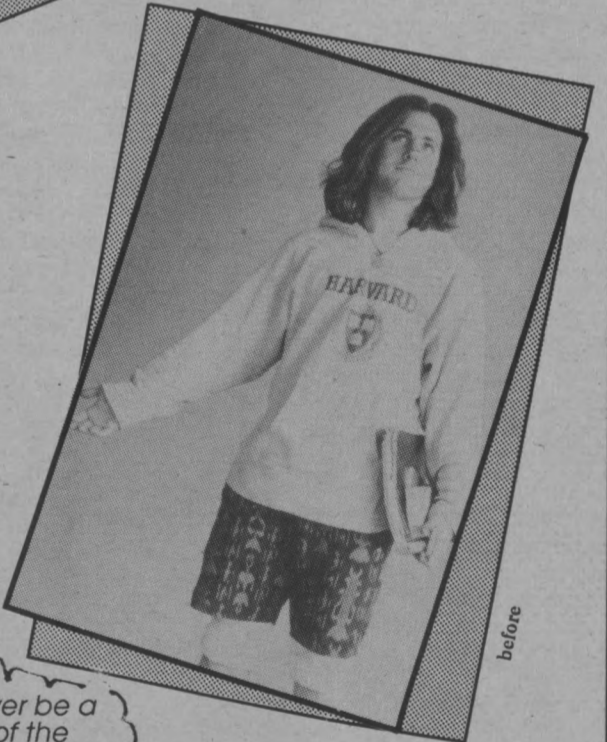

"I thought, how could I ever be a self-actualized woman of the nineties? I got no breasts, facial hair, and I'm a guy. But Playboy told me they could do anything with an airbrush."
-Seina Salaoman



You left to make your mark.
Now come home for the same reason.

At Nippon Motorola Ltd., we know the pride you feel in your American academic achievements, and your desire to apply your skills in a supportive environment when you return home.

We are a wholly-owned subsidiary of Motorola Inc., one of the world's leading manufacturers of communica-

tion systems, semiconductor devices, automotive and industrial electrical components, and information systems equipment.

As one of Japan's most highly respected American high-tech companies, our dynamic expansion means we can offer Japanese students who have studied in the U.S. a number of summer internships in the U.S. and Japan. Full-time career opportunities in both technical and non-technical positions are available at our Tokyo, Osaka, Sendai and Aizuwakamatsu facilities, and require superior Japanese communication skills, both written and spoken.

If you missed our on-campus visit and are interested in summer internships or full-time career opportunities with Nippon Motorola Ltd., please complete the coupon below or call collect (602) 994-6394.

had

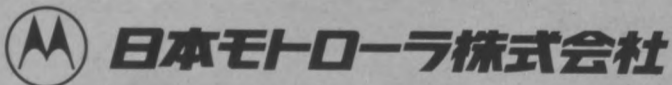

YES! I'm interested in pursuing a future in Japan with Motorola's wholly owned subsidiary -- Nippon Motorola Ltd., in the following areas:

ELECTRICAL ENGINEERING	SOFTWARE ENGINEERING	SUPPORT/PERSONNEL
ACCOUNTING & FINANCE	MIS/COMPUTER SCIENCE	

NAME _____
 ADDRESS _____
 CITY _____ STATE _____ ZIP _____
 PHONE NUMBER _____
 SCHOOL _____
 EXPECTED DATE OF GRADUATION _____
 DEGREE _____ MAJOR _____
 CITIZEN OF _____ VISA # and TYPE _____
 Where did you attend high school? Japan U.S. Other _____

Equal Opportunity Employer

Please fill out coupon and mail to:
Nippon Motorola Ltd.
College Relations
725 S. Madison Drive
Tempe, AZ 85281.





The Low Road of the Spirit — Materialism

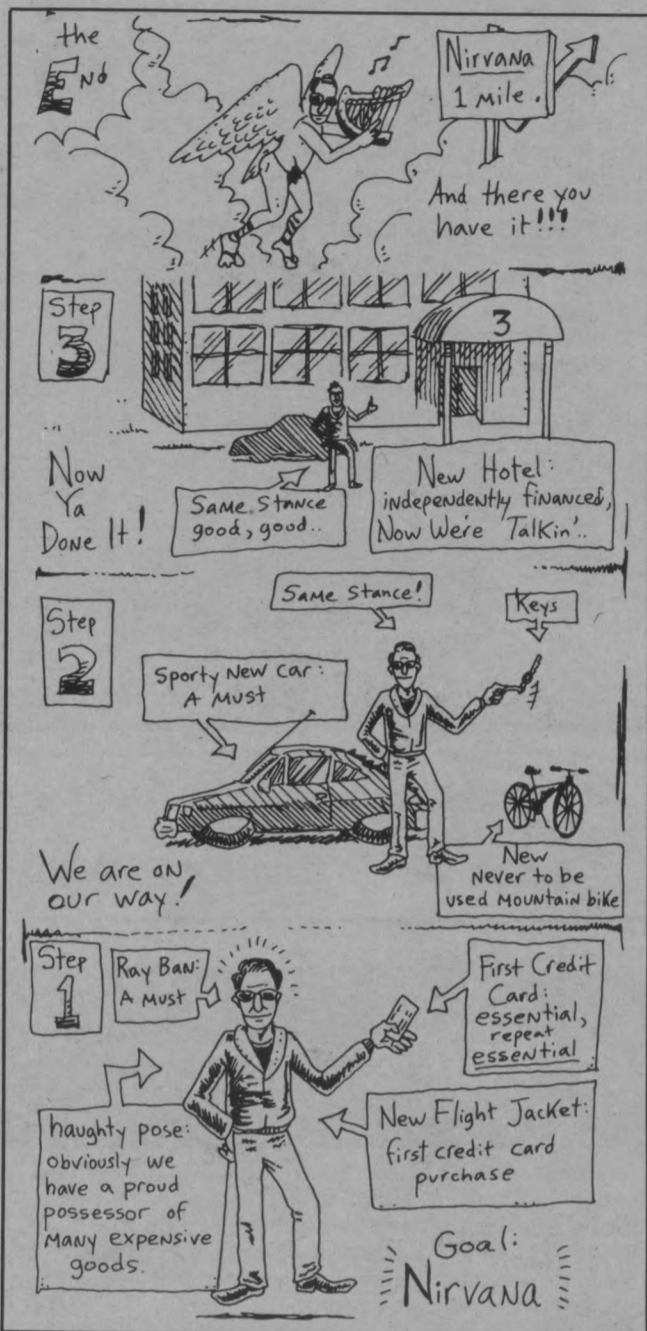

TODD FRANCIS/Daily Nexus

Eastern philosophies pursue perfection in terms which we of the West would probably have trouble understanding. For example, a Buddhist sect in Japan believes that perfection, inner and outer, should be manifested through the mastery of one of twelve disciplines, which include archery, sword-fighting, and tea service.

While we in the West admire these abstract manifestations of internal and external perfection, our material approach to the world leaves us little time to pursue these grand but financially worthless goals. So we at Friday Magazine have devised a philosophy which will combine the best of both possible worlds: rampant western materialism and tranquil eastern mystical holistic pursuit of perfection.

There will be Doubting Thomases, and even Apathetic Eddies (there's nothing worse than an eddy that goes nowhere) who question. Jump back, Dissenting Dale! We have reports of women experiencing material universal oneness with the aid of their credit cards at Nordstrom on several occasions! Yes! It can be done!

Would be money mongering monks must prepare themselves for the pain which is an intricate part of this philosophy. The pain of which I speak, Grass'opper, is experienced when carrying large amounts of packages from the mall.

A good start on the Nautilus circuit and acquaintance with those who are material masters (behemoth idiots), prepares the acolyte for the initial phase of training. Pick a mantra. This mantra will be repeated over and over during meditation in a droning nasal throb.

Acolytes should not aim too high with their mantras, Easterners might choose stylish-yet simple name brands, such as Levis, Gap, or perhaps L.L. Bean. West Coast devotees could start out with a low-key mantra such as G&S.

After mantras, one should move on to visualization and holistic imagery. Picture yourself in your favorite store buying an outfit or item of clothing that looks smashing on you, (your ladyfriends do this all the time, while you're picturing them in nothing, looking dashing). Price tags should never be present in holistic images because it is important to separate yourself from anything which may interfere with your material idealism.

Visualization is one of the most effective ways of tapping into the infinite amount of positive energy mystics tell us exists in the world; we merely have to tap into this energy to become what we desire.

Of course, visualization can get out of control (don't visualize anything that leads to masturbation too often). Be sure not to visualize yourself in items of clothing which someone else is wearing at the time. Our offices have been informed already of two instances in which visualizations resulted in telekinetic clothing removals which left the vis-

ualizee naked and in one instance led to the incarceration of the visualizer. Incarceration, you see, is the ultimate form of anti-material-mysticism; a state where one is physically denied access to material goods. The other case of clothing removal resulted in a pregnancy, but the visualizer was cleared of all involvement.

Once you have mastered the art of visualization, you are ready to combine the mystical with the material; you are ready to go shopping! As with the mantra, start simply at a stylish but not too financially crippling store. Stand in front of the store and visualize yourself entering the store and finding the perfect clothes for you in the store. You must become one with the store in order to experience the complete internal and external satisfaction of material mysticism.

Once again, starting with stores that are too expensive and trendy can interrupt your progress to the upper planes of material mysticism. Excessive trendy visualization can result in a malignant phenomenon which we call Nouveau Riche.

The key to material-mysticism, in a nutshell, is to be greedy and not care, but at the same time be stylish.

One last key word. Never worry about money in the long run. While at first you may not have the financial resources necessary to achieve material mystical bliss, if your visualizations are strong enough, money will have a way of falling into your pockets. And if not, there is always crime.

— Alex Salkever and Max Donnelly

The MultiCultural Center

Gardens & Cultures:

Chinese Gardens—"Abode of Scholars and Immortals"

Islamic Gardens—"Gardens of Paradise"

English Gardens—"Natural Gardens"

Friday, March 2 / 12:00 pm / Free

UCSB MultiCultural Center

Presented by the UCSB MultiCultural Center

For more information call the UCSB MultiCultural Center at 961-8411.

University of California at Santa Barbara

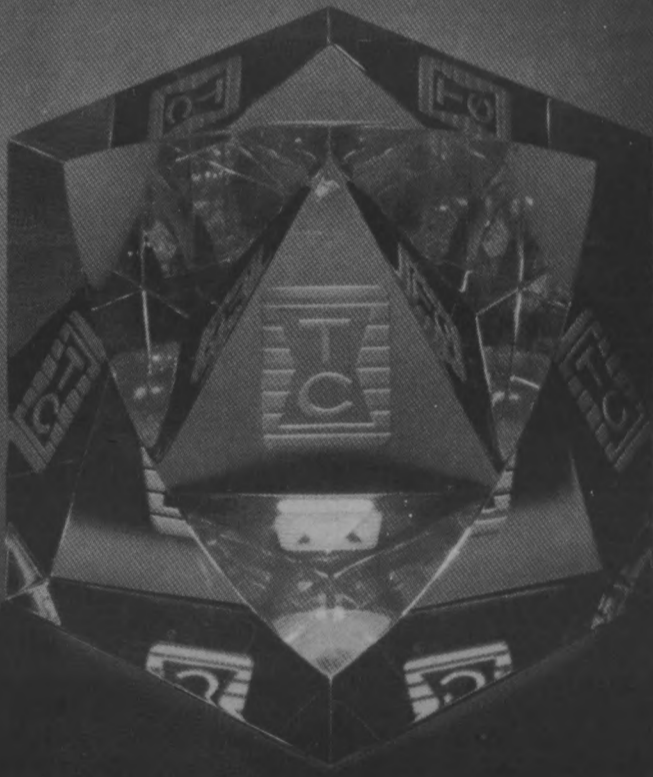

The Possibilities Are Infinite!...

Career Opportunities with Tandy Corporation/Radio Shack

The leader in consumer electronics technology offers careers in sales, marketing and retail management. Radio Shack has been bringing affordable high-technology products from the drawing board to the marketplace since 1921. Today we have more than 7,000 outlets nationwide and corporate net sales for fiscal 1989 exceeded \$4.2 billion. We design and manufacture many of the products we sell. The widely acclaimed Tandy® computer line, along with Radio Shack's other advanced-technology products and brand names, are examples of our

leadership in consumer electronics. Tandy's continued growth creates new sales and sales management career positions which lead to future advancement opportunities. Radio Shack is currently seeking sales-oriented and goal-motivated people desiring a challenging opportunity to participate in one of today's most dynamic companies. If you're looking for this type of career opportunity and think you can measure up to the best, we may have the key to your future. Write to us today for application information!



Tandy Corporation/Radio Shack

Tom Fulmer
Dept. 01-0321
12821 Knott Street • Garden Grove, CA 92641
EQUAL OPPORTUNITY/AFFIRMATIVE ACTION EMPLOYER



Express Yourself says Madonna, wearing very little, and putting her potential men through gladiatorial trials. Self-expression, the motto of the eighties, the hallmark of the "me" generation. Is this it? Is self expression the key to self justification?

First off, it isn't so easy to go out and do it. How do you know when you are doing something that is really you, or if you are just doing something that would impress others? What if the real you just wants to impress everyone?

Second, once you do it, what then? What if you express yourself, and there is no one there to hear it, did you make a noise?

Finally, there you are, pouring yourself out to the universe, and then it's over. You're poured out, the universe failed to register your presence, since you did not bother to use a known, conventional language, and it's time to go back to your job, which is selling insurance.

The Will-Fixed or Free

So you don't know what to do with your life, some people would say it doesn't really matter. What you do was determined at the beginning of time. Either God has already thought everything out, or the chain of causation goes all the way back to the beginning of time. We here at FM believe that humans must be free, because they have an infinite capacity for stupidity. However, we don't feel that we should impose this point of view without at least looking at some of the alternatives.

- According to B.F. Skinner, everything you do is determined by the conditioning which sets up your behavior. Just as a rat can be taught to press a lever, humans are taught to open doors, flush toilets, and perform elementary brain surgery.
- According to Calvinism, a certain number of human beings were picked out be-

fore they were even born to live good lives and be saved afterwards. The rest of us are condemned to hell after a brief fling with sin, guilt, and degradation.

- St. Augustine said that God knows what will happen to us, yet we are free to do what he knows we are going to do. This is like everybody knowing that UNLV would win the game. God becomes the universal, "Didn't I tell you that would happen?"
- Einstein said that God's dice are always loaded. While a few people interpreted this comment as an ethical evaluation of God (Like the computer, God cheats), the more standard interpretation is that God did not allow any chance in the universe, only the appearance thereof. However, if God predicted everything, did he know about Einstein's hair?
- Pure fatalism suggests that the causes for everything, including Einstein's hair,

existed at the beginning of the universe, the already discussed big bang. According to this theory, the original cosmic egg contained not only the song, "Ina-Godda-Davida," but all of the variations people have thought of while trying to make sense of the lyrics.

- Some believe that we are free because of Quantum physics. According to this theory, anything random could happen at any moment on a very small scale. However, when dealing with large groups the results become predictable. Think about it though, which is more predictable, the residents of Itoka, Iowa, or a large mass of New Yorkers?
- If, however, we are truly free, then we must be capable of action that is not dependent on the preceding conditions, in other words we must be able to do things that make no sense. Hanging around the Daily Nexus proves this to be the case.

— D. Jeffers

Living for Sex

There was a point in humankind's existence that his purpose in life was to procreate, to make a smaller version of him or herself that would carry on his or her traditions and roots. Those days are gone. No longer are we like the mighty salmon, fighting Mother Nature, swimming up stream, only to kick the bucket after spawning.

We still like sex, mind you. It's just that our perspective has changed. Quick algebra will clarify this.

Goal of life = Make Babies = Sex + Conception.

Therefore,

Goal of life = Sex + Conception

However,

1990's = AIDS + Careers + Etc. = Contraception.

And,

Contraception + Conception = 0

In Conclusion

Goal of Life + 1990's = Sex + Conception + Contraception

Or

Goal of Life = Sex

As this formula clearly indicates, in 1990 we are here to hump. This message is backed up by the media, the one true bellwether (whatever that is) of society.

— Denis Faye

"A foolish consistency is the hobgoblin of small minds."
—Ralph Waldo Emerson, (Dead)

Monday 3/5
7-9-11 pm
Campbell Hall
\$3.00
Spons. by UCSB
Tournament
Waterski & AS
Underwrite

the fabulous baker boys

INDIANA JONES
and the
LAST CRUSADE

Saturday 3/3
8, 10:30 pm
IV Theatre \$3.00
sponsored by: Entrepreneurs

EDDIE MURPHY **RICHARD PRYOR**

HARLEM NIGHTS

Friday 3/9 7-9-11 pm
IV Theater \$3.00
Spons. by Phi Sigma Kappa

SANTA BARBARA

SWAP MEET

907 S. Kellogg, Goleta

Great Fun • Great Bargains

EVERY SUNDAY
7 AM TO 3 PM

FOR INFORMATION 964-9050

Fake Letters To FM's Amy

Dear Amy,
I dreamt that my mother was staring down upon me at the kitchen table repeatedly preaching the necessity of a good breakfast to start my day. She stood there with this bottomless pan of raisin oatmeal scooping and scooping. I awoke in my sleep a driven man, realizing that the downfalls of modern civilization, poverty, wealth, disease, irregularity, all of them, stemmed from our break with the institution of breakfast. This understanding reached the core of my being. The very next week I started a job with a food development company in their cereal department. I came in on the ground floor, affixing bar codes to the left side of the boxes. My sheer passion for the business soon catapulted me to the upper echelon of cereal engineering. My team went on to launch such cereal successes as Barbie cereal, Teenage Mutant Ninja Turtle Cereal, and our newest super-hero, Batman Cereal. I hold at least 50% of the market with those products alone, but I cannot help but feel that success has led me astray from my convictions. I am a socially conscious person at heart. I give to the arts, sponsor children in other countries, I even bought tickets to the Farm Aid Concerts. I know that cereal is my calling, but I feel as if I have bitten the very hand I feed.

Help! I am a prostitute to cereal prestige.
Ralston J. Purina.
Ralston,
Your story became all too common in the late 80s. A well meaning professional steps into the marketplace and somewhere on the escalator ride to the top, the glare of success and the opportunity to acquire a greater share of the market blinds the poor soul and they forget their roots and run rampant through the industry poisoning children with sugared cereals. But, these are the 90s, the age of capitalizing on your conscience. You can have the best of both worlds my misguided little cereal magnet. Just polarize yourself in another direction. Leave the kiddie accounts to the young guys and move on to a more enlightened market. There are a multitude of concerned cereal consumers out there and I am sure the numbers are growing every day. Tap their market and reconcile your estranged convictions with your desire for wealth and power. A few cereal smashes just waiting to happen: Ecological Earth Cereal with blue granola earths and oat bran rain forests (just right for George Bush, the environmental president), Amnesty International Cereal with sugar-free, no-salt figures of Sting, Tracy Chapman, and current political prisoners. The slogan could read "Free the prisoners from injustice — Free your body from indigestion with sugar-free, salt-free AIC.", and Dead Poet's Society cereal with corn puff letters that spell out "Carpe Diem." Concisely, Mr. Purina, you should not waste your gift, but neither should you waste your guilt. Make them both work together, for you! (...And try to stop whining.)

Amy,
I want to speak up for we the people who choose to exercise our right to be lazy. We've been receiving a slew of bad publicity lately from the active folks out there and I'd like to rebut. I swear if I hear the word couch potato again I'll be forced to buy a stratalounger just to challenge the little suckers to get more creative with their slang. I am fairly tired of seeing aerobic addicts jumping around everywhere in their g-string leotards, butts flapping, checking the labels of everything they eat. But do I resort to name calling? And as much as the naturally high hip-

sters chat of their disgust with our lifestyle, they don't seem to have tired of watching Al Bundy and family going through life with a cheap beer in hand and nothing much on the brain. So why don't they get off their high exercycles and admit that Keystone is a better beer "calorie for calorie" than Heineken any day.

Norman,
Why do I sense that you were the type of student who, when given a topic for a paper, would take a long hard look at your professor and pick the subject that would most displease them? To your credit, you have managed to prod me in a sore spot. But seeing as I'm not feeling too terribly unbiased today, I believe that I shall introduce you to a higher source of discredit to your argument, one Emanuel Kant. Kant was a practicing philosopher who developed a little theory on the justness of one's actions. For Kant it all revolved around contradiction.

If you act one way, assume that everyone will follow suit and there will be a world of people doing your thing. If in their doing this, your original purpose is defeated, then you have a contradiction. It is a simple idea and a quick test. Let us envision for a moment, a Norm World, one with everyone just as unmotivated as you. One large scale version of Normal Illinois with eight pro-wrestling channels on cable. But television would only air for two hours a day because the wrestlers would have to avoid exertion, and nobody would want to install the cable and ... well Norm, I'm afraid we have a contradiction here. My advice to the Stratalounger Hounds of the world is to "Stop scoffing and start appreciating what 'active folk' have done for you." Who do you think invented cheap beer?

Dear Amy,
I am appalled at the level of apathy that the students of UCSB have reached. With the recent passing of the twentieth anniversary of the bank burning one is made sorely aware of the lack of verve with which current Isla Vista residents lead their contemptuous lives. They are all spoiled little pre-yuppies destined to follow the dollar down whatever path it leads them, never once considering following their convictions (what convictions?) I suppose there is little hope for them getting out there and raising some hell when they can't even pull off a decent hunger strike?!
Timothy Leary

Tim,
Obviously you were not on the 6600 block of Del Playa on Monday night after the UNLV game. The students united and took over the streets gathering around blazing dumpsters filled with flammables symbolic of the injustices they face. They discarded their material treasures in a display of their distaste for modern morality.

Beds were burned in protest of the removal of the condom row at Student Health Services, and fences in a symbolic gesture of unity and fraternity. Couches were set ablaze to show that the students will get out of their living rooms and into the streets to light for what is dearest to their hearts, basketball.

Young men and women were observed throwing their Automated Teller Machine cards into the blaze, an act mirroring closely the events of those twenty years ago. The youth of today is as volatile as any generation of college students. Given the proper provocation, nothing will keep them from disturbing contemporary banking practices.
Amy



Friday Magazine Writer Psych Test

When you decide what to do with your life to give meaning to your existence, to make your mark on the world, don't forget about writing for Friday Magazine. Of course, you must have the correct psychological balance, not too healthy, not too psychotic, just sort

C. A huge fallacy
D. The Washington monument and circumcision

2. During a lecture on health habits, the instructor refers to "mastication", some people giggle because:
A. They thought he said "matriculation".

tifying salt and pepper shakers.
C. Is subjectification the opposite of objectification?
D. Whose idea was it to give women dictionaries?
Sensitivity to the pain and suffering of others.

body.
C. Don't you know to put those round paper things on the toilet seat first?
D. That's what happened to everyone who voted for the UCen/RecCen.

Cultural Awareness

1) You are watching a noted performance artist. Suddenly, apparently as part of his act, he begins urinating on the audience. If you are a real insider, you know that you should:
A. Yell "fire", and urinate on

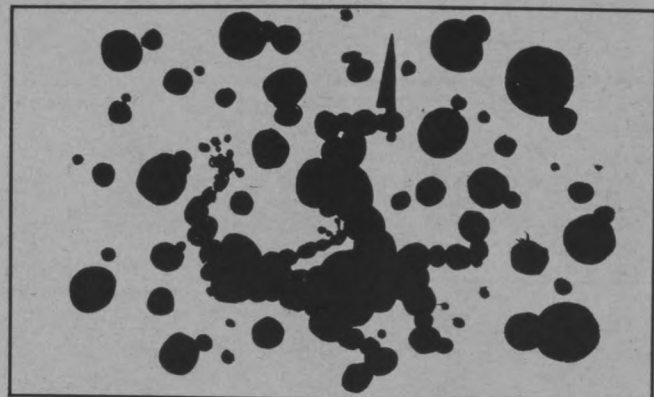

TODD FRANCIS/Daily Nexus

See anything violent!

of neutrally neurotic. Try the following quick quiz.

Sexual sensitivity. FM writers have been known to laugh at double and even triple entendres that sail over (or under) less enlightened people. This section will tell us how many jokes you will get.

1. Everytime you see Storke Tower, you think of:
A. White Imperialism
B. A big goofy bird with a long neck and funny beak

B. One of the TA's is making a gesture which means he is mastering a baton.
C. The instructor has something between his teeth.
D. They are really laughing at you because everyone knows you masticate.

3. When FM gets nasty letters about the "objectification" of women, your first, uncensored thought is:
A. I don't object to women. At least not good looking ones.
B. I guess I'll stick to objec-

1. A UCSB student, who is in your physics discussion section gets drunk and falls to his death while trying to scale Storke Tower. Before grief overcomes you, you have a quick flashing thought, which you immediately suppress. The thought is:
A. I wonder if his term paper was almost done, I wonder where it is.
B. Let's see, 60 feet at 32 feet per second squared....
C. What does it sound like when you throw a watermelon off a ladder?
D. Why did they end Storke with an E? Is it like when they add an E to Shoppe?

2. A close personal friend of yours is handing out flyers in front of the UCen. When you walk up, he/she turns a little red, and you grab a flyer which advertises a support group for one of the old fashioned "social diseases." To alleviate his/her obvious embarrassment you say:
A. It's a good thing I never objectified you (with you?).
B. I knew someone who had big boils all over his/her

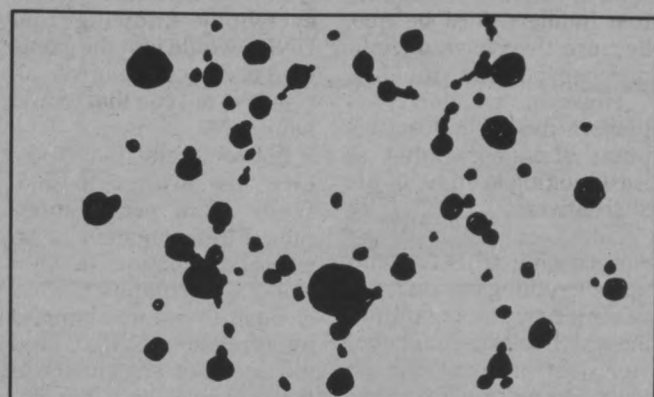

DEBBIE URLIK/Daily Nexus

Don't squint at this!

when suddenly, at three in the morning, he/she calls up and says he/she has a gun in her mouth and she/he will pull the trigger unless you take her/him/it back. To calm him/her/what down, you say:
A. I'm sorry, you must have a wrong number.
B. Your just going through a phase.
C. Can you call me back in about an hour, I'm in the middle of something.
D. Don't talk with your mouth full.

the seat in front of you.
B. Applaud politely.
C. Plug an extension cord into the wall, and wave the open end in the direction of the artist.
D. Say "Excuse me, I'm double parked." Leave.

— D. Jeffers

Where The New Bucks Are

If you want to mark off your little spot in the universe, leave a lingering aftertaste of your existence in the historical record of mankind, the simplest and most accepted method is through a career.

Of course the choice of career is important. After all, the contributions of even the most successful certified public accountants have not been etched in the annals of time. Some of the most promising career paths for the next decade are as follows:

Vote checker — Look at Jimmy Carter. After a high profile career which seemed destined to mark him down in history as the hick of capital hill, Jimmy has risen back to the top by watching people vote in Central America. If he gets good enough, they may send him to Chicago.

Sidewalk chalk artist — More and more movements are utilizing chalk outlines to represent people who have died from various causes. With a world population in the neighborhood of 5 billion, all of whom are expected to die, the market outlook is exceptional.

Duck washer — After every oil spill, one of the first tasks



KAREN PEABODY/Daily Nexus

is to scrub the beaches, coastlines, and wildlife. America shows ever greater reverence for independence through automobiles, so the oil prospects should hold out.

Vegetable counselor — Don't laugh, everyone knows that plants grow better when certain types of music are played or when they are spoken to affectionately. What about the plants that get the wrong music, or the abusive language? You can start a special clinic for plants of Metallica fans.

Animal lawyer — Face it, animals are gaining more rights daily. They can already expect the law to protect them from cruel owners, and they can even inherit. Soon, the final step will be taken, and the law will attempt to regulate inter-species relations. Lawyers will make millions hammering out who has the right to eat whom and with what level of cruelty.

Recycling engineer — Recycling is the only way to go, but many of the really difficult problems have to be solved. Can we come up with a recyclable toilet paper or should we develop a corn husk sanitizer?



URLIK PEABODY/Daily Nexus

Total service — Some of the drugged out, concert deafened masses are bound to grow up and get rich. Why should these people wear unsightly hearing aids when they can hire you to shout in their ears? Why should they continue to take life-threatening drugs when they can hire you to do it for them?

Stand-up accuser — The nineties will continue to be guilt ridden and religion is losing some of its fire and brimstone pull. In all likelihood, the stand-up comic will slowly give way to the stand-up accuser who can yell at us and tell us how bad we are. This trend is already showing in the humor of Sam Kinneson, Howie Mandel, and Gallagher.

Media reader — Why should network anchors have to be able to read? They certainly don't understand. In the future, anchorpeople will become even better looking, with just a touch of respectability, while slowly losing basic skills like reading. Teleprompters will be replaced by little receivers in the ear. If the anchors forget how to talk, we can always use computer animated lip-synching with readers doing voice over.

— D. Jeffers



DEBBIE URLIK/Daily Nexus

ALI BOBS

Falafels Gyros

956 Emb. D. Norte

PINK FLOYD THE WALL

Friday March 2, 7-9-11 pm
IV Theatre

sponsored by UCSB Triathlon & A.S. Underwrite

Friday March 2, 7-9-11 pm
IV Theatre

\$3.00

Uncle Buck

Friday March 2, 7-9-11 pm
Campbell Hall

\$3.00

sponsored by: Black Pre-Health

Sunday March 4 3pm, 7pm, 9 pm
IV Theatre \$3.00

sponsored by IV Youth Project & Epsilon Sigma Alpha

THE BEAR

The Asian American Charity Committee presents the ...

1st Annual

Charity Ball

A semi-formal dance to benefit local charity

TIME: 9 p.m. - 1 a.m.
DATE: 3 March 1990
PLACE: Carrillo Dining Hall
TICKETS: \$7 pre-sale
\$8 at the door

Asian Pacific American Student Union Kapatirang Pilipino
Asian Student Coalition Korean Student Association
Chi Delta Theta Lambda Phi Epsilon
Chinese Student Association Undergrad Chinese Society
Hong Kong Student Association Vietnamese Student Association

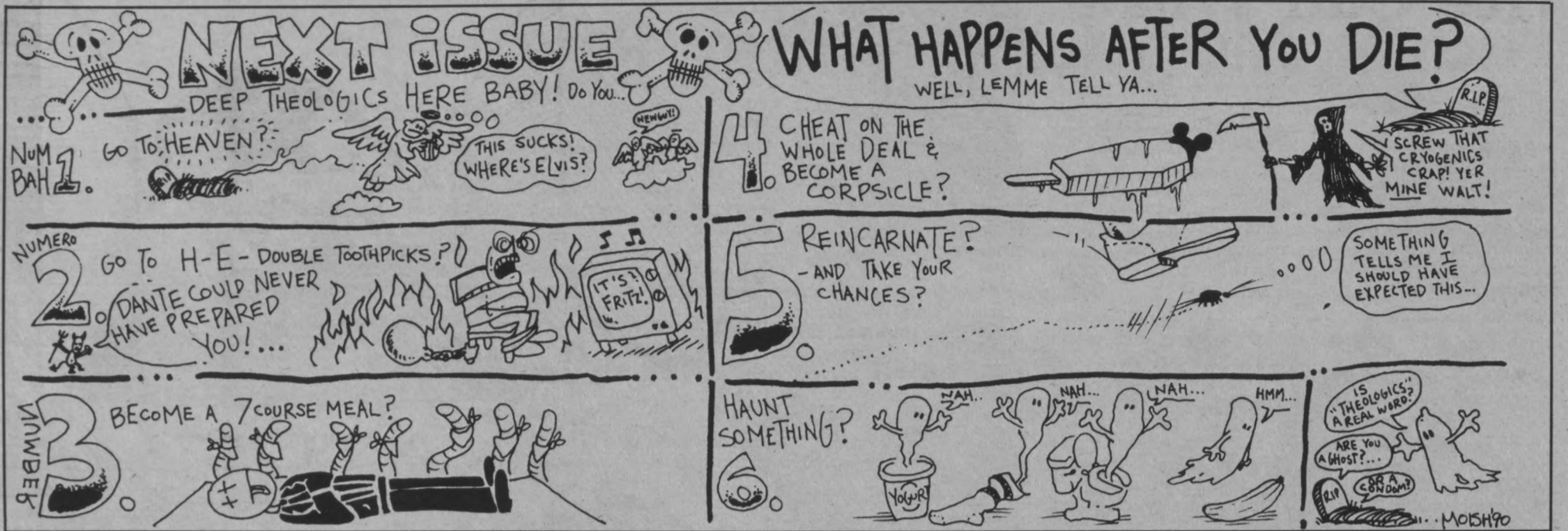

MOISH/Daily Nexus

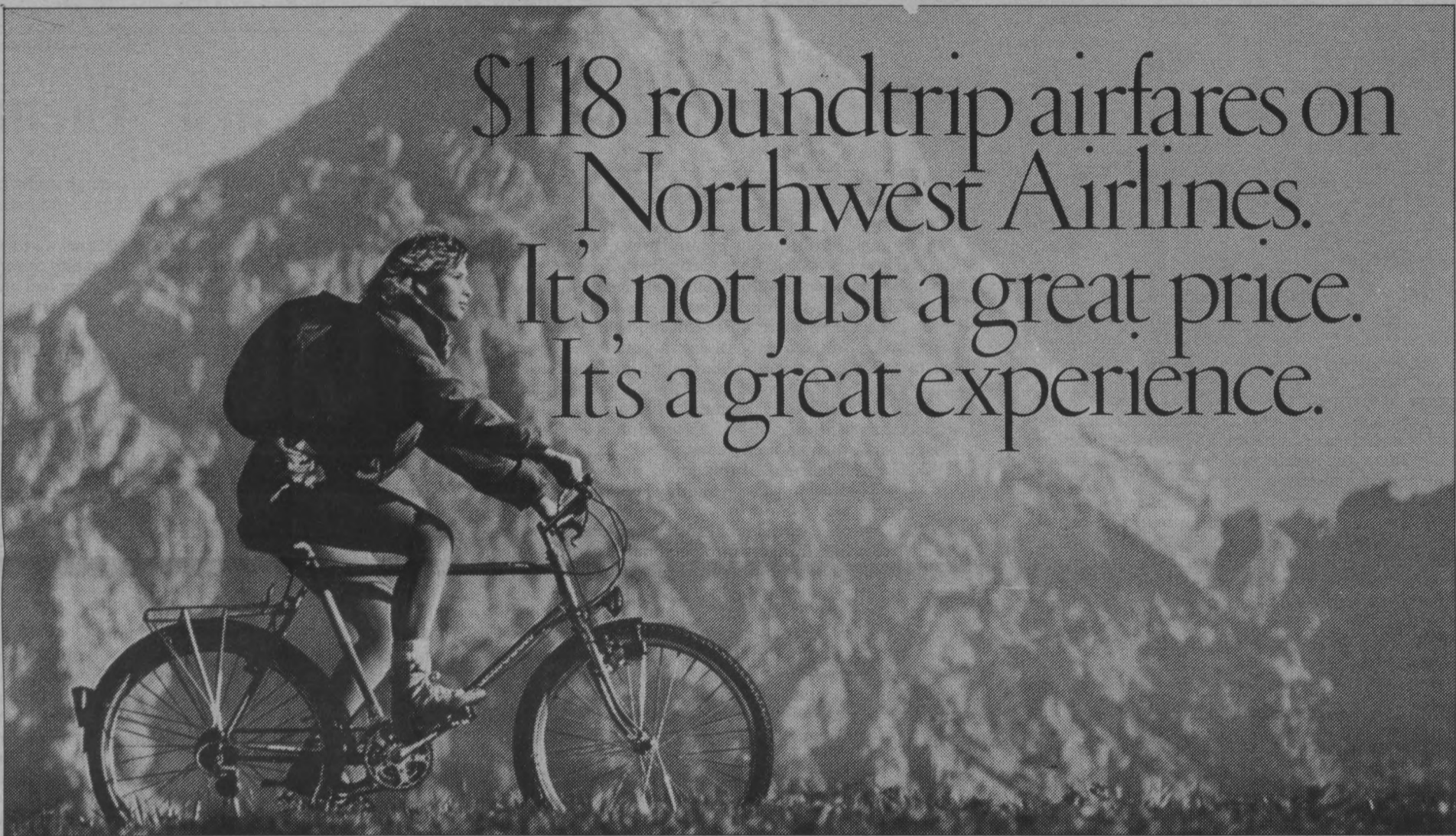

\$118 roundtrip airfares on Northwest Airlines. It's not just a great price. It's a great experience.

Only for student American Express® Cardmembers.

Apply for the American Express® Card. Then get ready to take off. In search of adventure, action—or just simply to escape.

American Express and Northwest Airlines have arranged these extraordinary travel privileges on Northwest—exclusively for student Cardmembers:

- CERTIFICATES VALID FOR THE PURCHASE OF TWO \$118 ROUNDTRIP TICKETS—to many of the more than 180 cities in the 48 contiguous United States served by Northwest. Each certificate is good for a six-month period, and they will arrive within six weeks after you receive the Card. Current Cardmembers will automatically receive their \$118 certificates by March 15, 1990 provided they are still full time students.*

- 10% OFF ANY NORTHWEST FLIGHT—with your own personalized discount card, valid through January 1991 on all Northwest and Northwest AirlinK flights. (This discount is not applicable to the \$118 student certificates and other certificates, promotional or special status airfares.)

- 2,500 BONUS MILES TOWARDS FREE TRAVEL—when you enroll in Northwest's WorldPerks® Free Travel Program.

AND NOW BECOMING A CARDMEMBER IS AS EASY AS A TELEPHONE CALL. Just pick up the phone, call 1-800-942-AMEX, and talk to us. We'll take your application and begin to process it immediately. (If you have your banking information handy, like your account number and bank address, it will help

speed the process.)

Keep in mind that our Automatic Acceptance Program makes it easier for you to become a Cardmember now, as a student, than it will ever be again.

And remember that as a Cardmember you'll enjoy all the exceptional benefits and personal service you would expect from American Express.

So don't miss out on a world of great experiences. Pick up the phone. Apply for the Card. And start packing!



Membership Has Its Privileges®



APPLY TODAY
1-800-942-AMEX



*If you are already a student American Express Cardmember and have a question about this program, please send your written question, a copy of your student ID and class schedule to: American Express, P.O. Box 35029, Attn: Student Marketing, Greensboro, NC 27425. Fare is for roundtrip travel on Northwest Airlines. Tickets must be purchased within 24 hours after making reservations. Fares are nonrefundable and no itinerary changes may be made after purchase. Seats at this fare are limited and may not be available when you call. Travel must originate by certificate expiration date and be completed within 60 days of that date. Travel may not be available between cities to which Northwest does not have published routings. City fuel surcharges not included in fare from Boston (\$2.50), Chicago (\$5.00), Denver (\$2.00) and Florida cities (\$2.00). Certain blackout dates and other restrictions may apply. For complete offer details, call 1-800-942-AMEX. ©1990 American Express Travel Related Services Company, Inc.